

Revision History		
Rev. Code	Date	Description
A	2021-01-19	创建原理图
B		1、 2、 3、 4、
C		

#	修改日期	修改内容
1		
2		
3		

# Easy-HC32F460 Rev.B

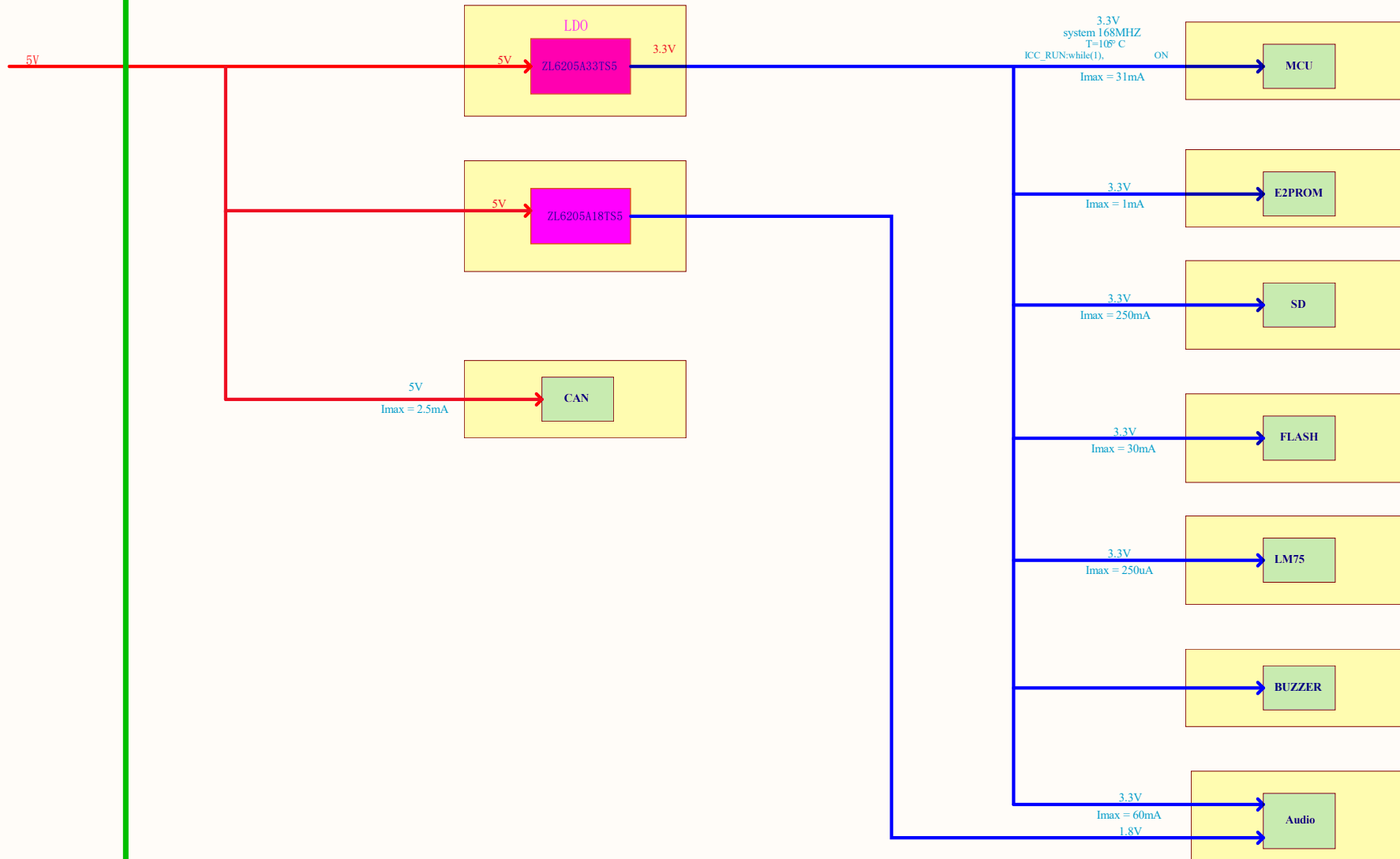

#	修改日期	修改内容
1		
2		
3		

# 3. MAIN

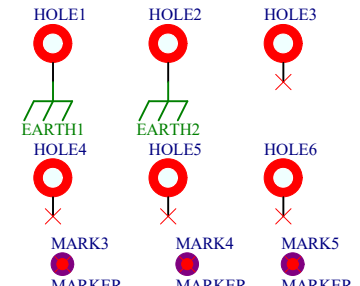
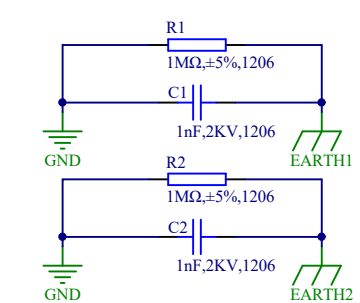
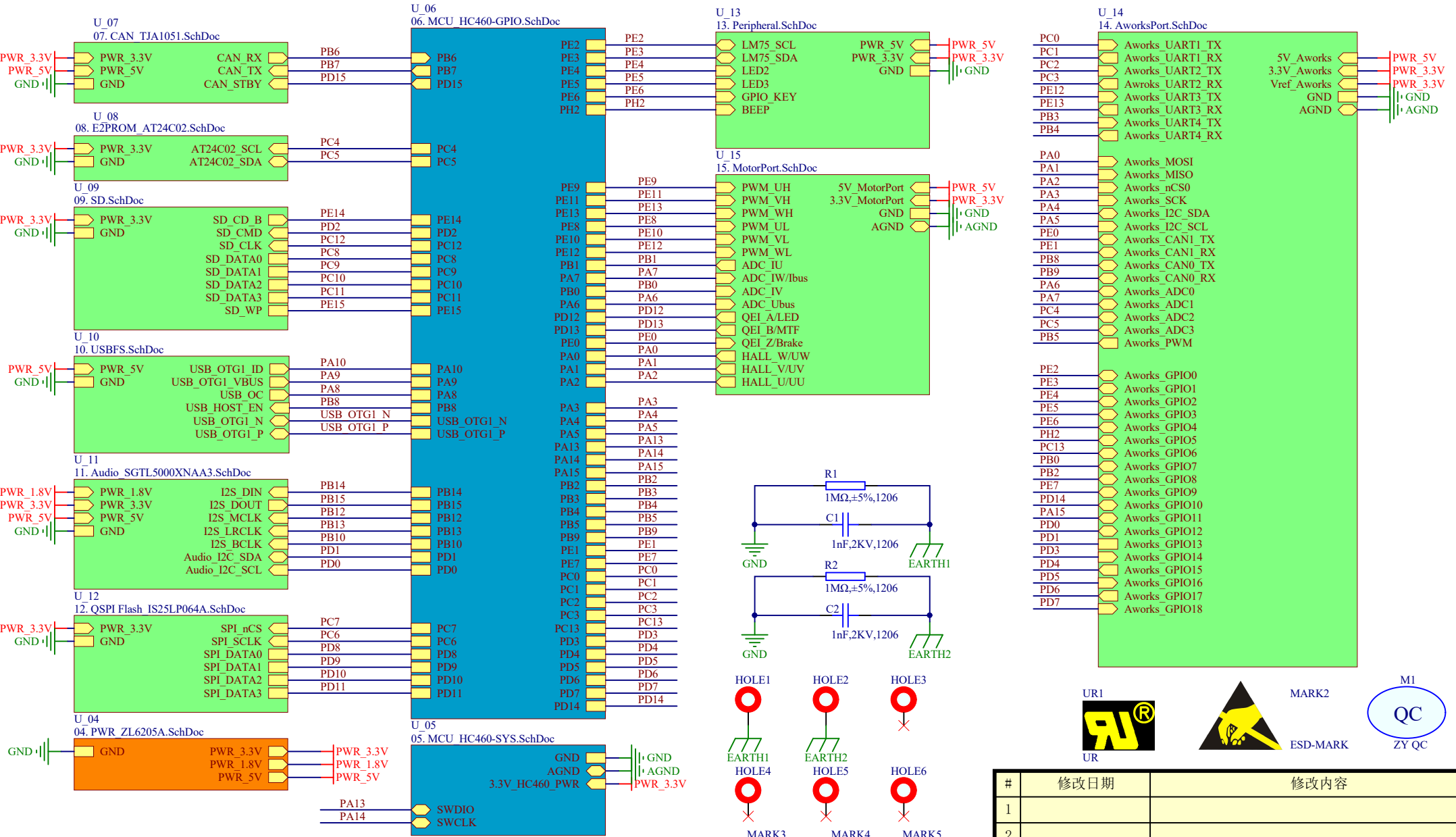



UR



MARK2  
ESD-MARK



M1  
QC  
ZY QC

#	修改日期	修改内容
1		
2		
3		

# 4. PWR\_ZL6205A

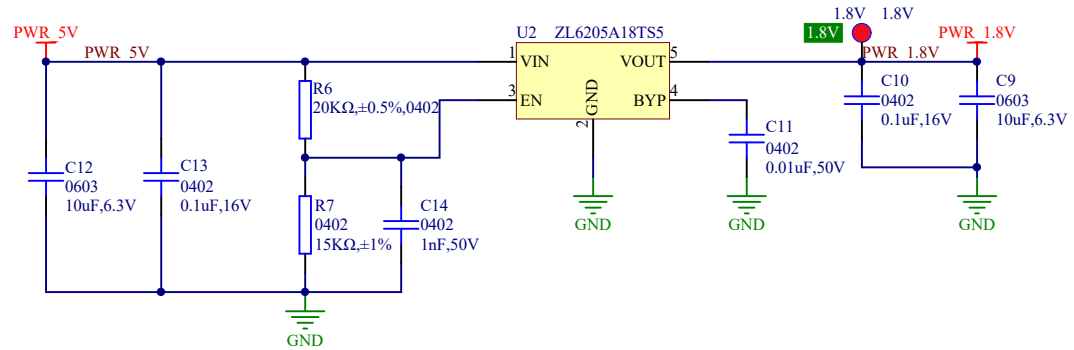
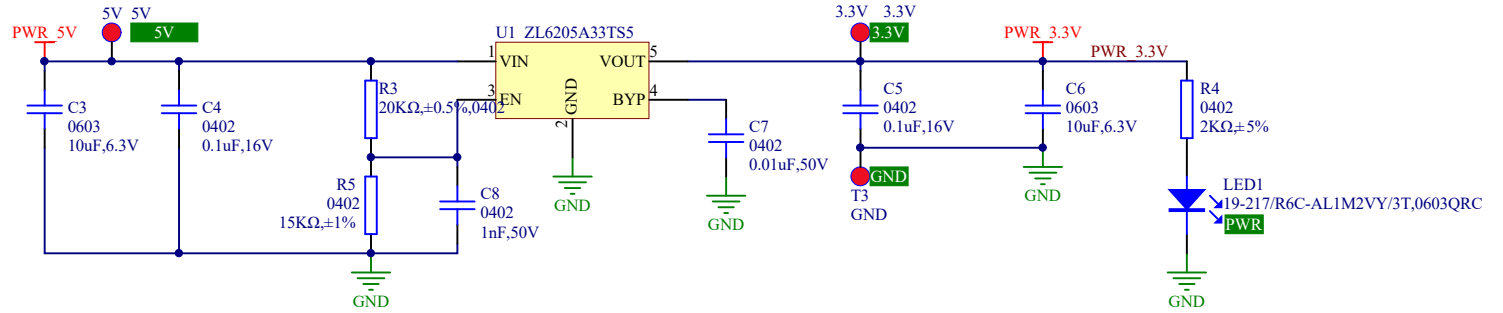
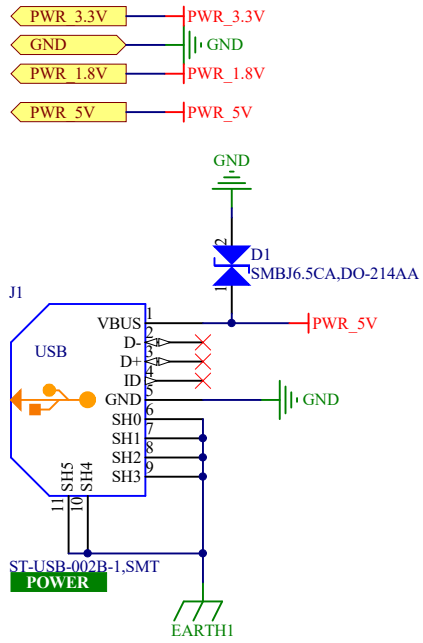

#	修改日期	修改内容
1		
2		
3		

# 5. MCU\_HC460\_SYS

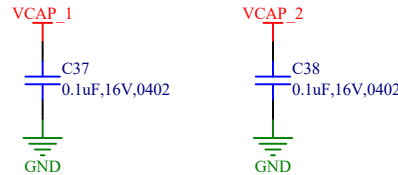
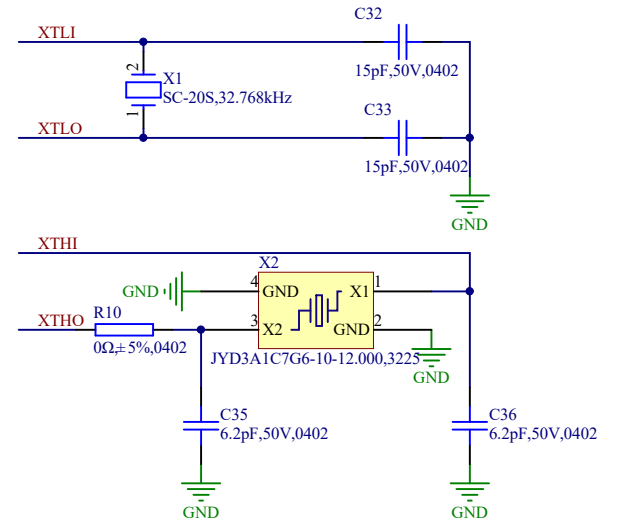
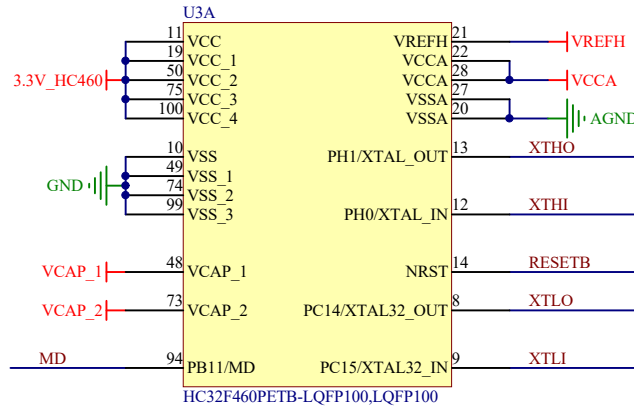
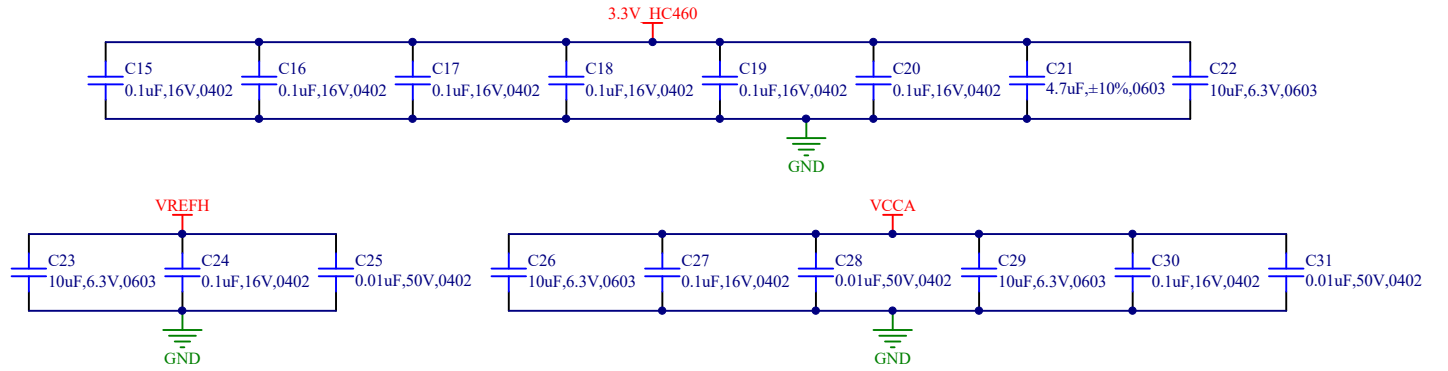
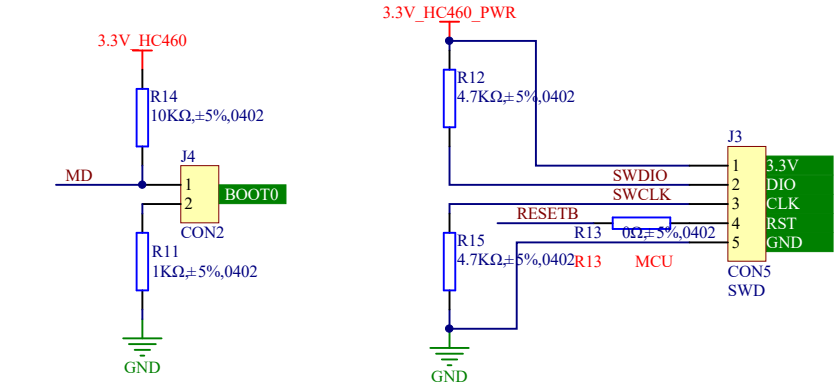
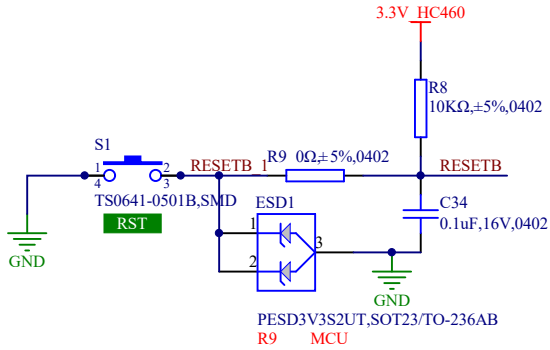
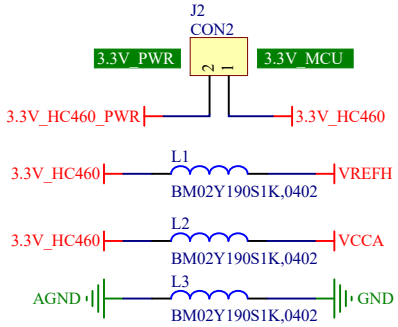
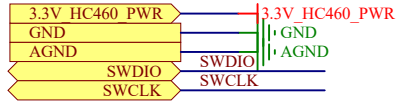

#	修改日期	修改内容
1		
2		
3		

# 6. MCU\_HC460\_GPIO

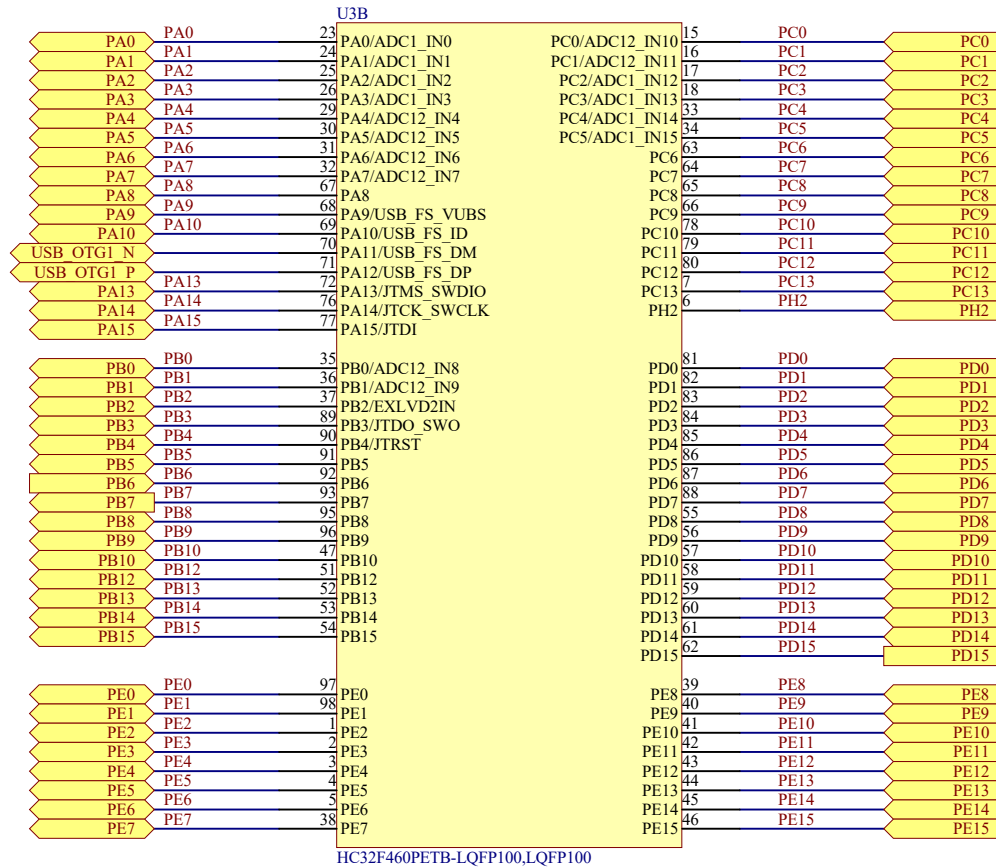

#	修改日期	修改内容
1		
2		
3		

# 7. CAN\_TJA1051

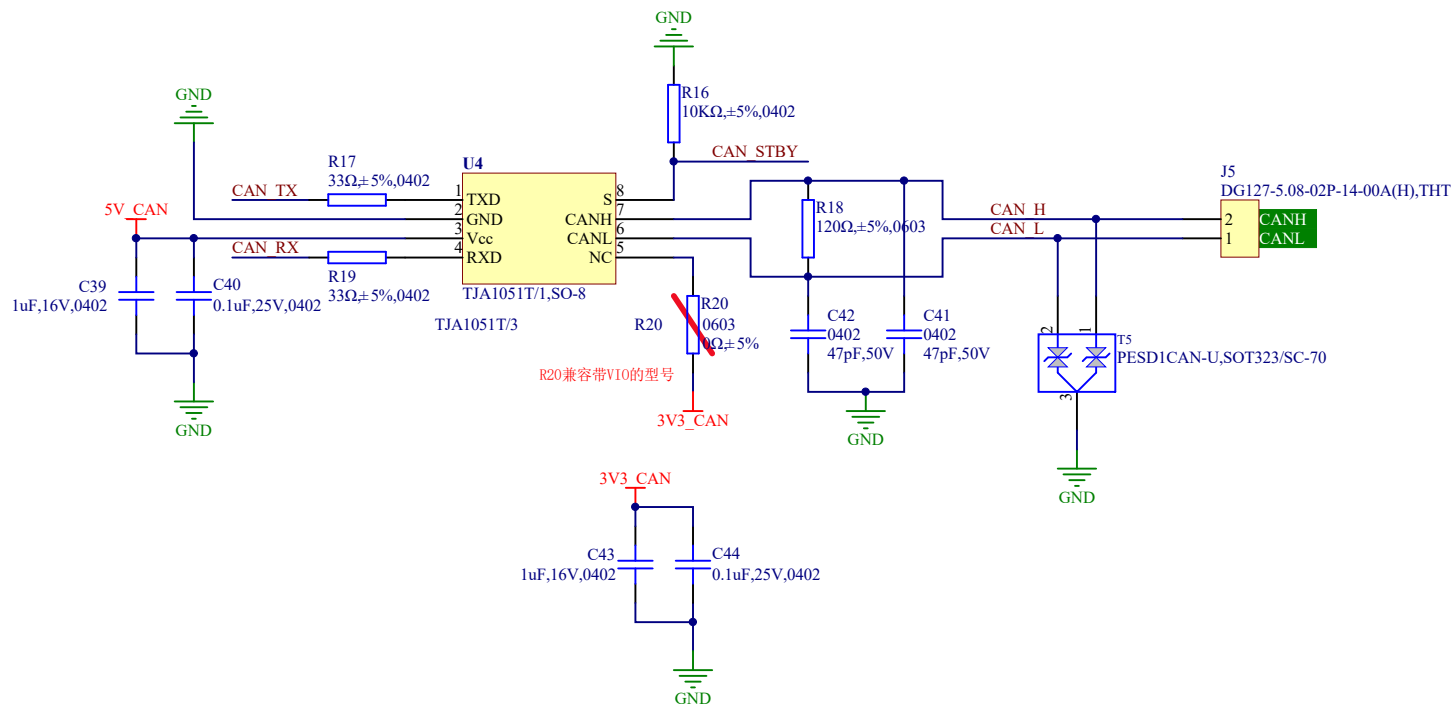
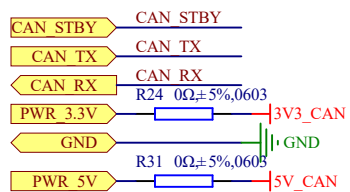

#	修改日期	修改内容
1		
2		
3		

# 8. E2PROM\_AT24C02

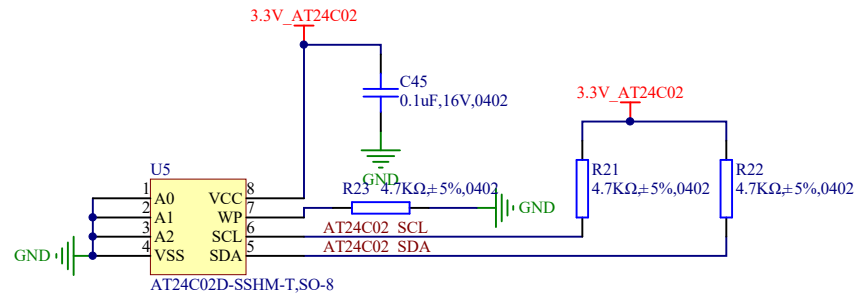
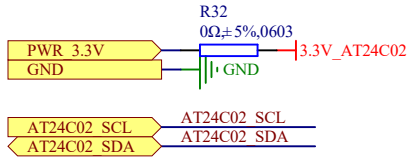

#	修改日期	修改内容
1		
2		
3		



# 9. SD

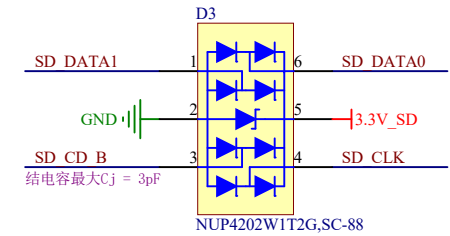
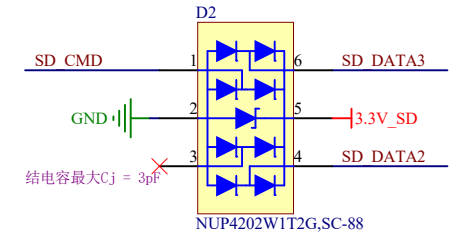
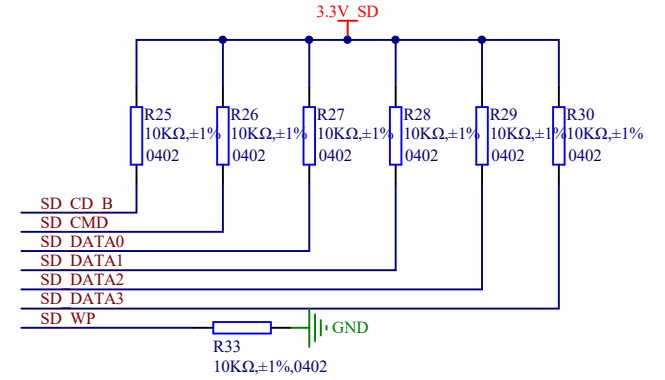
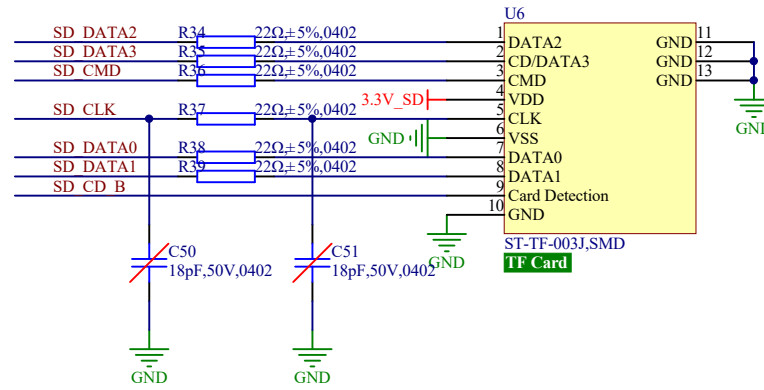
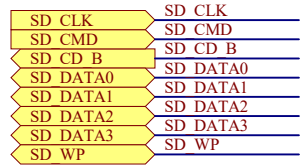
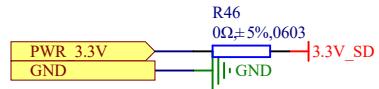

#	修改日期	修改内容
1		
2		
3		

# 10. USBFS

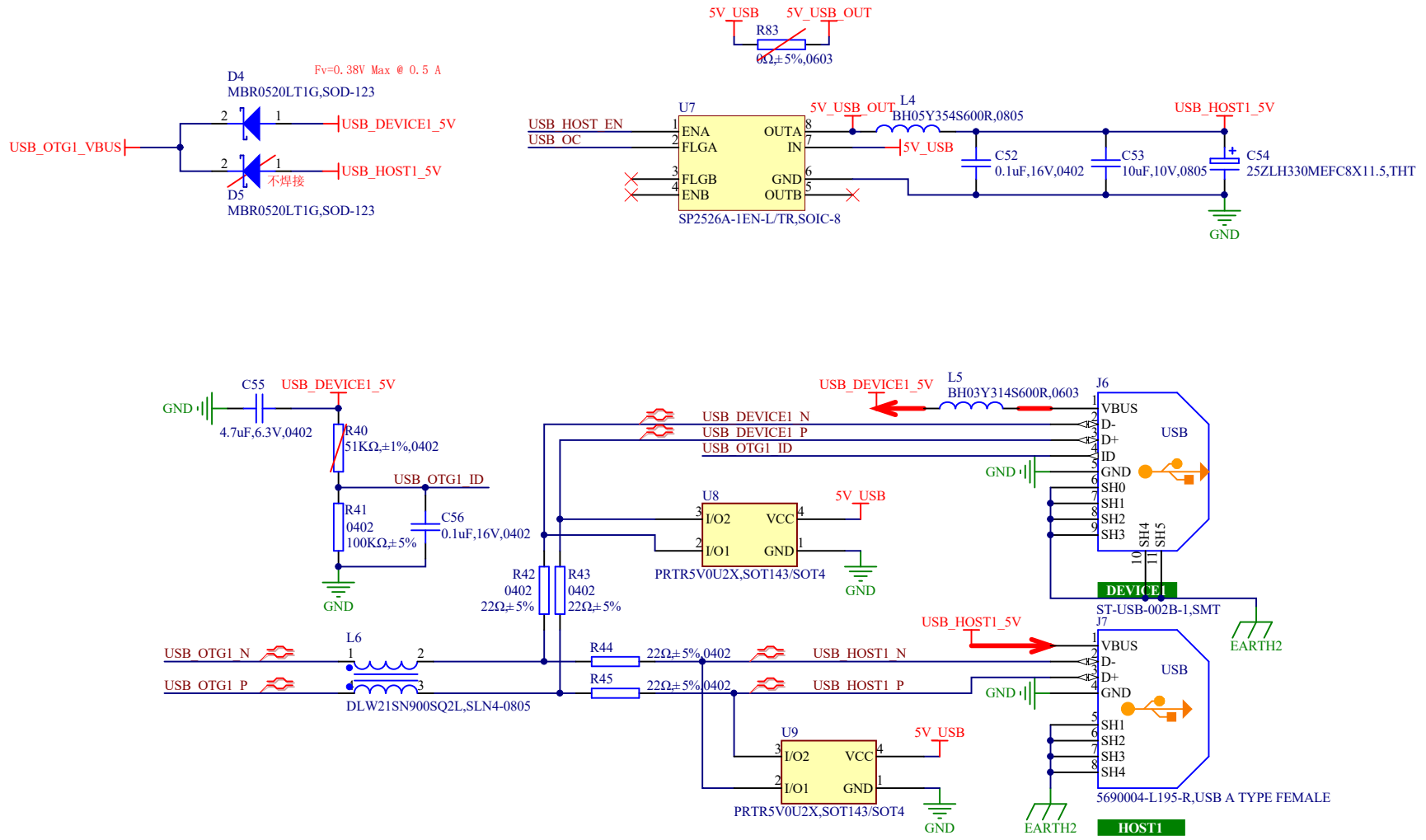
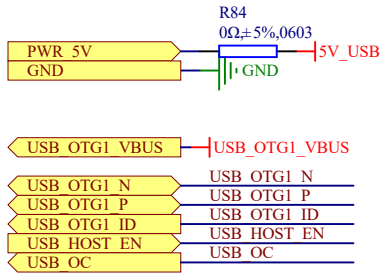

#	修改日期	修改内容
1		
2		
3		

# 11. Audio\_SAI

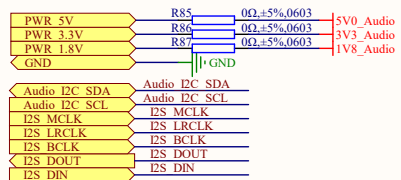

可换电阻改变I2C地址:  
0x01 010R/W  
I2C地址:0x14/0x15

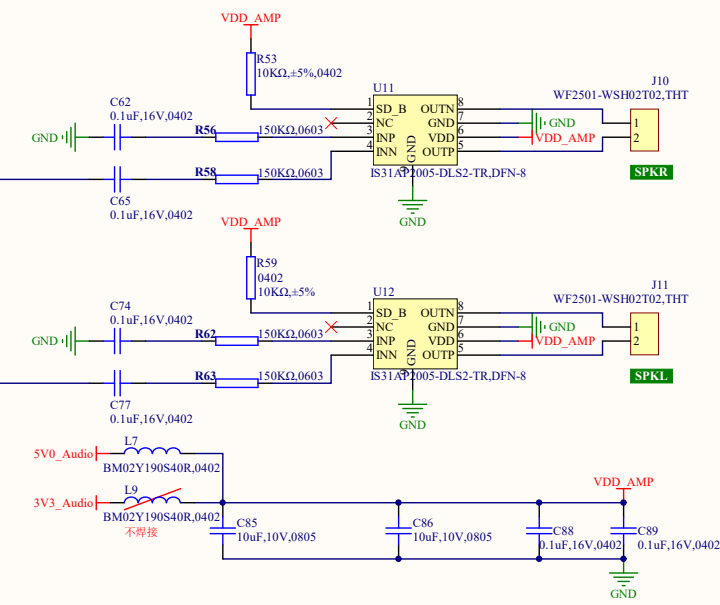
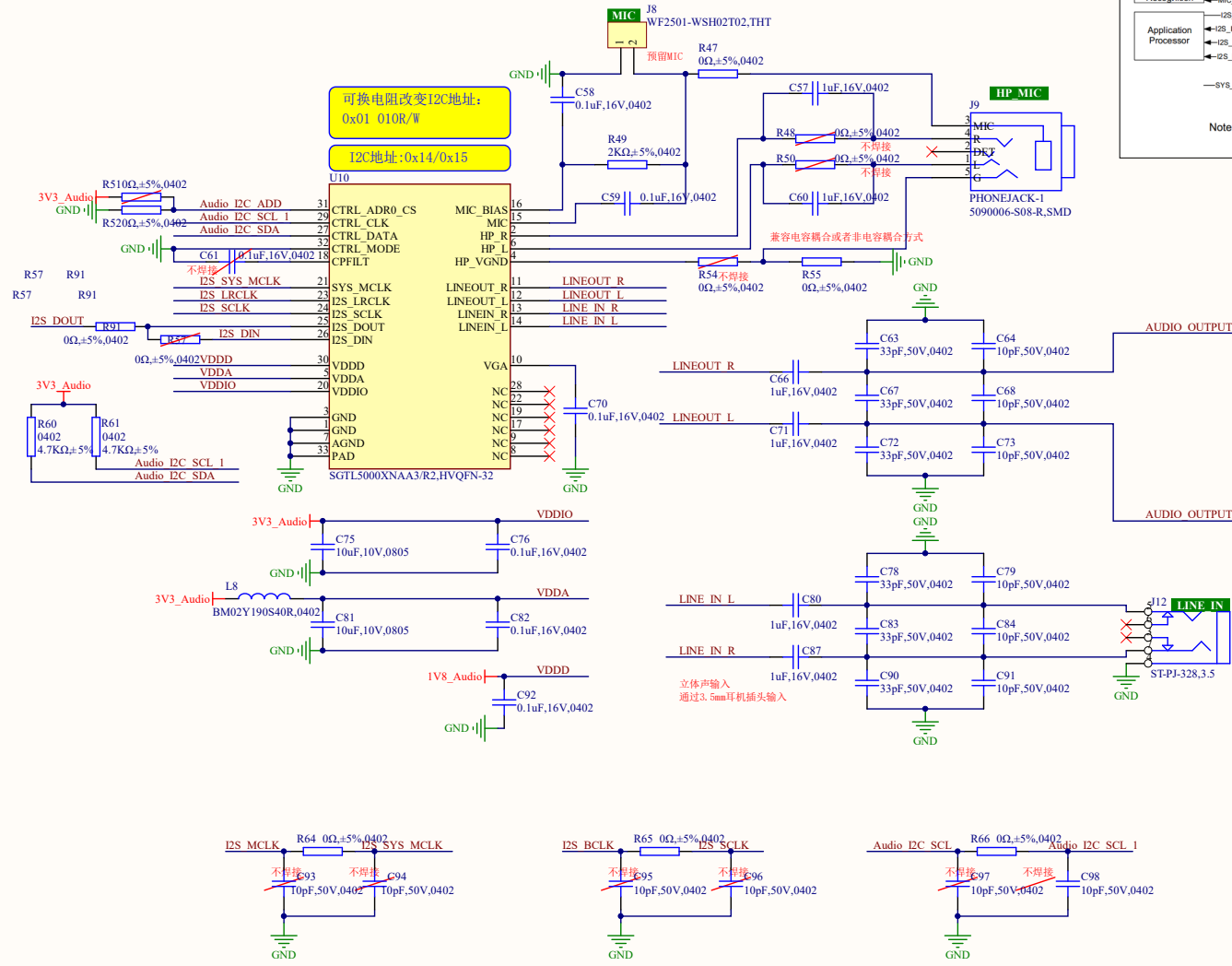
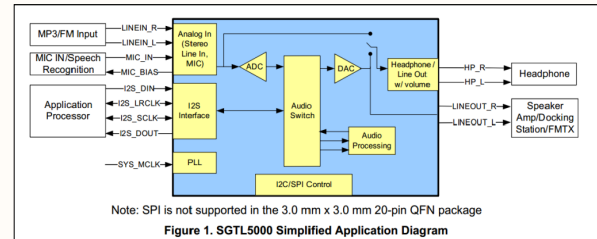

#	修改日期	修改内容
1		
2		
3		

# 12. QSPI\_Flash\_IS25LP064A

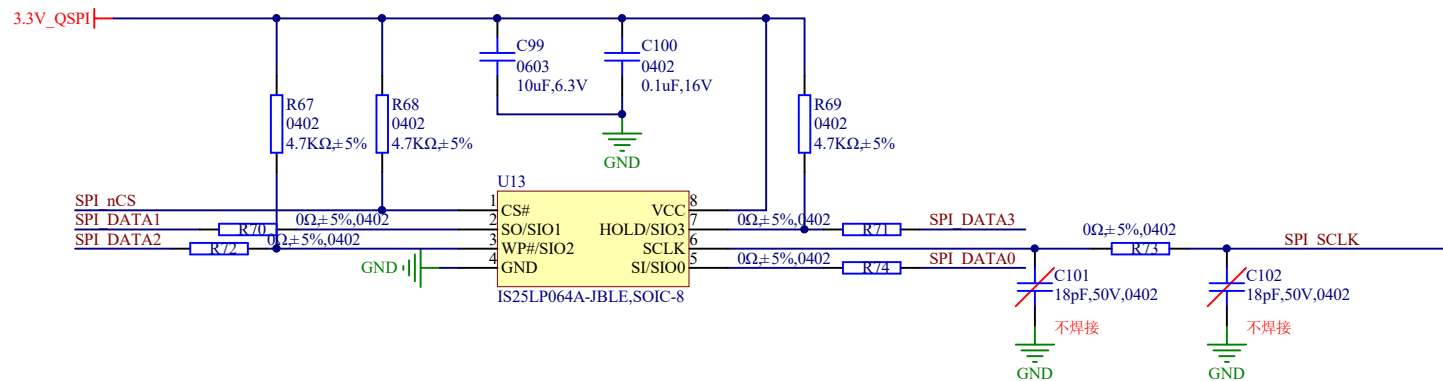
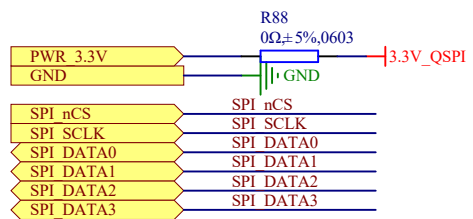

#	修改日期	修改内容
1		
2		
3		

# 13. Peripheral

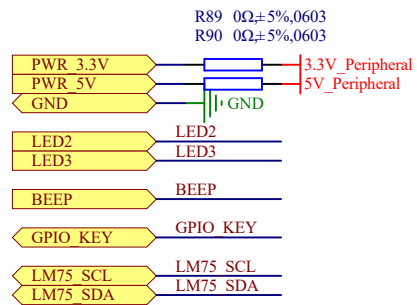

## LED电路

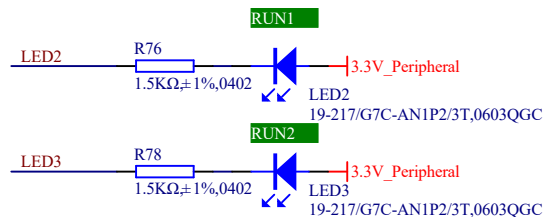

## 蜂鸣器电路

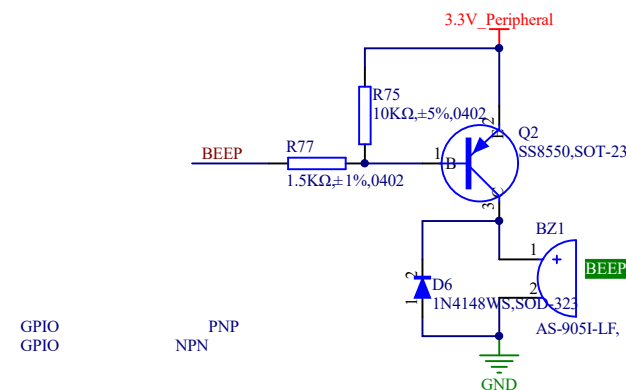

## 按键与加热电路

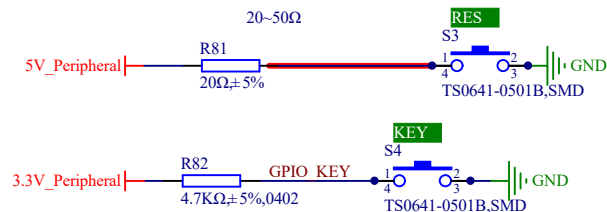

## 数字温度传感器电路

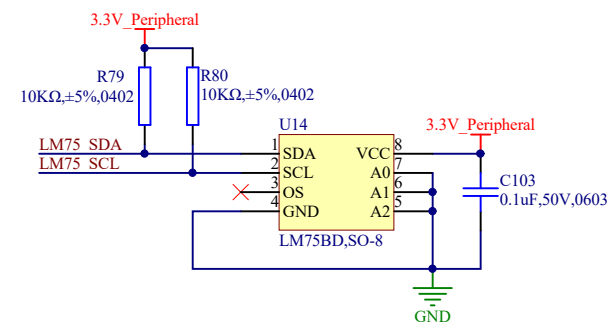

#	修改日期	修改内容
1		
2		
3		

# 14. AworksPort

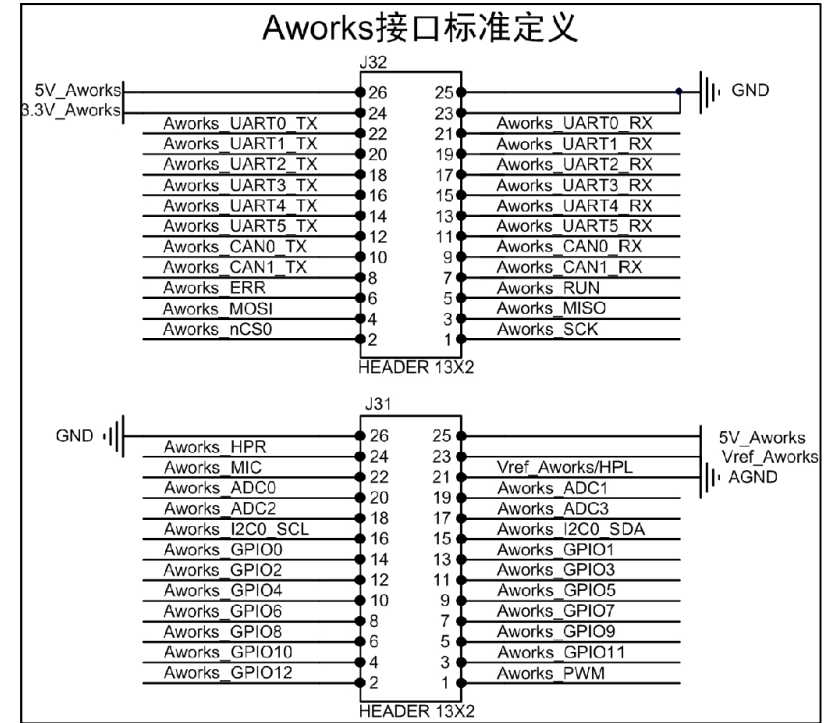
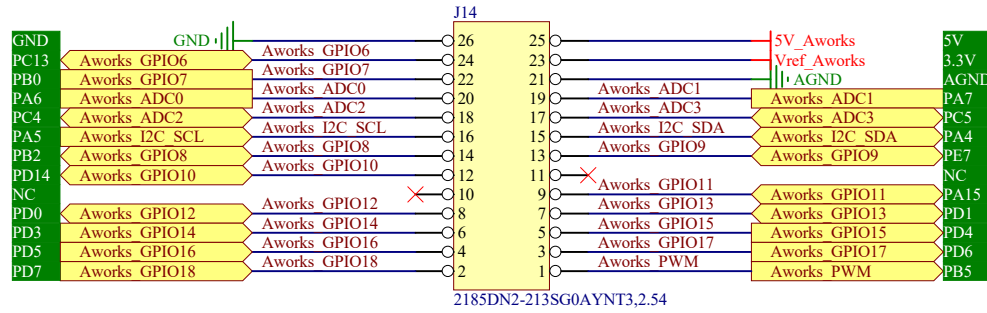
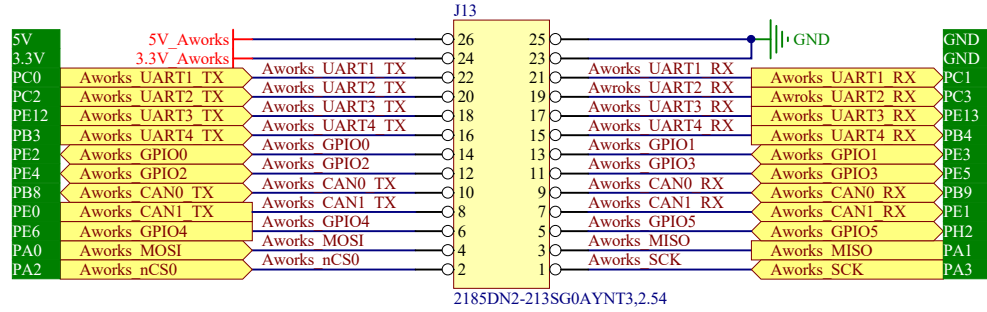
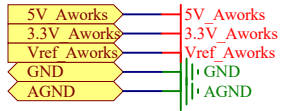

#	修改日期	修改内容
1		
2		
3		

# 15. MotorPort

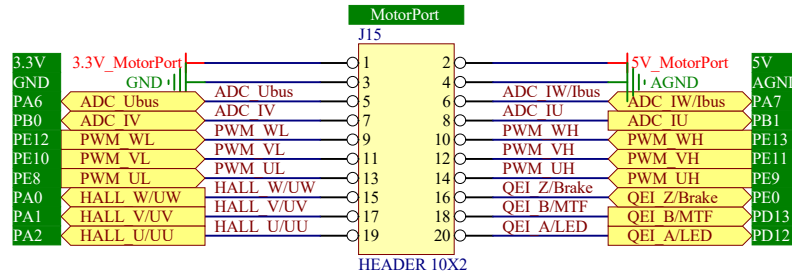
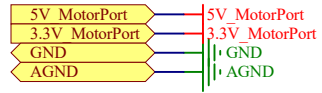

#	修改日期	修改内容
1		
2		
3		