

IS31FL3746A

24-RGB MATRIX LED DRIVER

December 2018

GENERAL DESCRIPTION

The IS31FL3746A is a general purpose 18×n (n=1~4) LED Matrix programmed via 1MHz I2C compatible interface. Each LED can be dimmed individually with 8-bit PWM data and 8-bit DC scaling (Color Calibration) data which allowing 256 steps of linear PWM dimming and 256 steps of DC current adjustable level.

Additionally each LED open and short state can be detected, IS31FL3746A store the open or short information in Open-Short Registers. The Open-Short Registers allowing MCU to read out via I2C compatible interface. Inform MCU whether there are LEDs open or short and the locations of open or short LEDs.

The IS31FL3746A operates from 2.7V to 5.5V and features a very low shutdown and operational current.

IS31FL3746A is available in QFN-32 (4mm×4mm) package. It operates from 2.7V to 5.5V over the temperature range of -40°C to +125°C.

FEATURES

- Supply voltage range: 2.7V to 5.5V
- 18 current sinks
- Support 18×n (n=1~4) LED matrix configurations
- Accurate color rendition
 - 8-bit PWM
 - 8-bit dot correction
 - 8-bit global current adjust
- SDB rising edge reset I2C module
- 29kHz PWM frequency
- 1MHz I2C-compatible interface
- Individual open and short error detect function
- 180 degree phase delay operation to reduce power noise
- Spread spectrum
- De-ghost
- QFN-32 (4mm×4mm) package

APPLICATIONS

- Hand-held devices for LED display
- Gaming device (Mouse, Mouse MAT etc.)
- IOT device (AI speaker etc.)

TYPICAL APPLICATION CIRCUIT

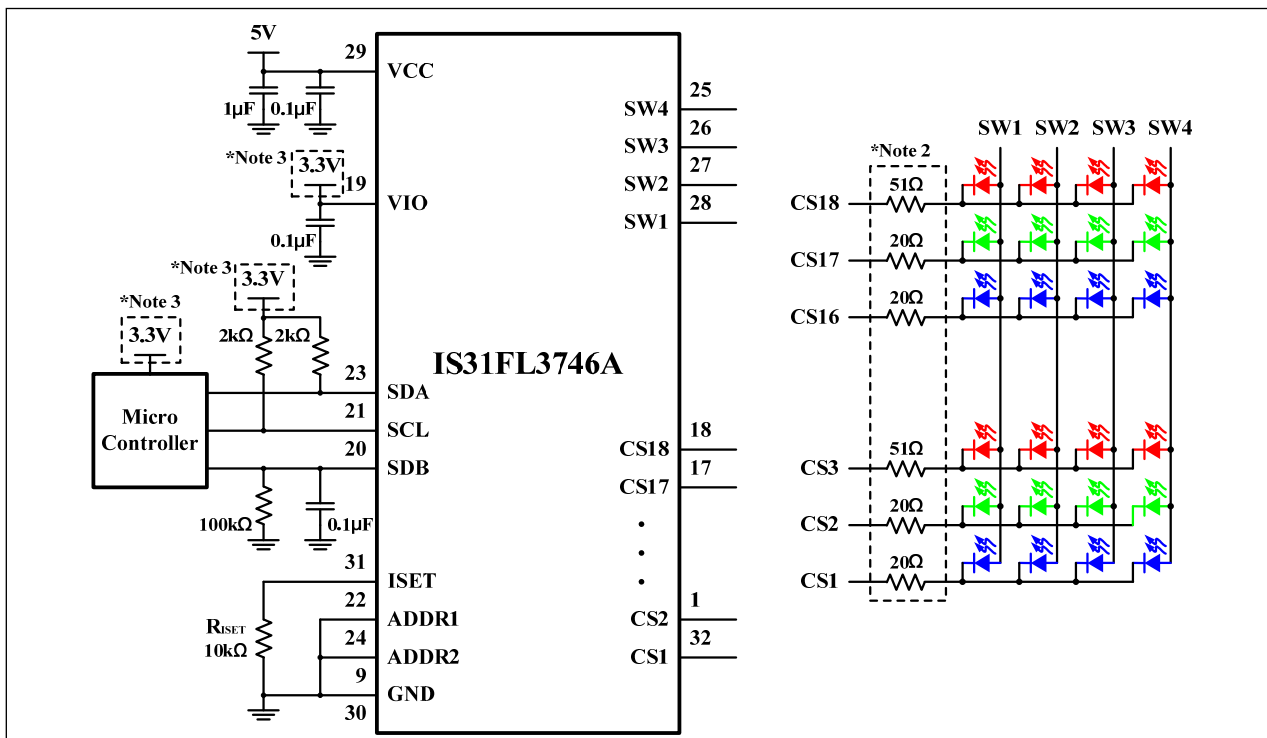

Figure 1 Typical Application Circuit: 18×4, 24 RGBs

IS31FL3746A

TYPICAL APPLICATION CIRCUIT (CONTINUED)

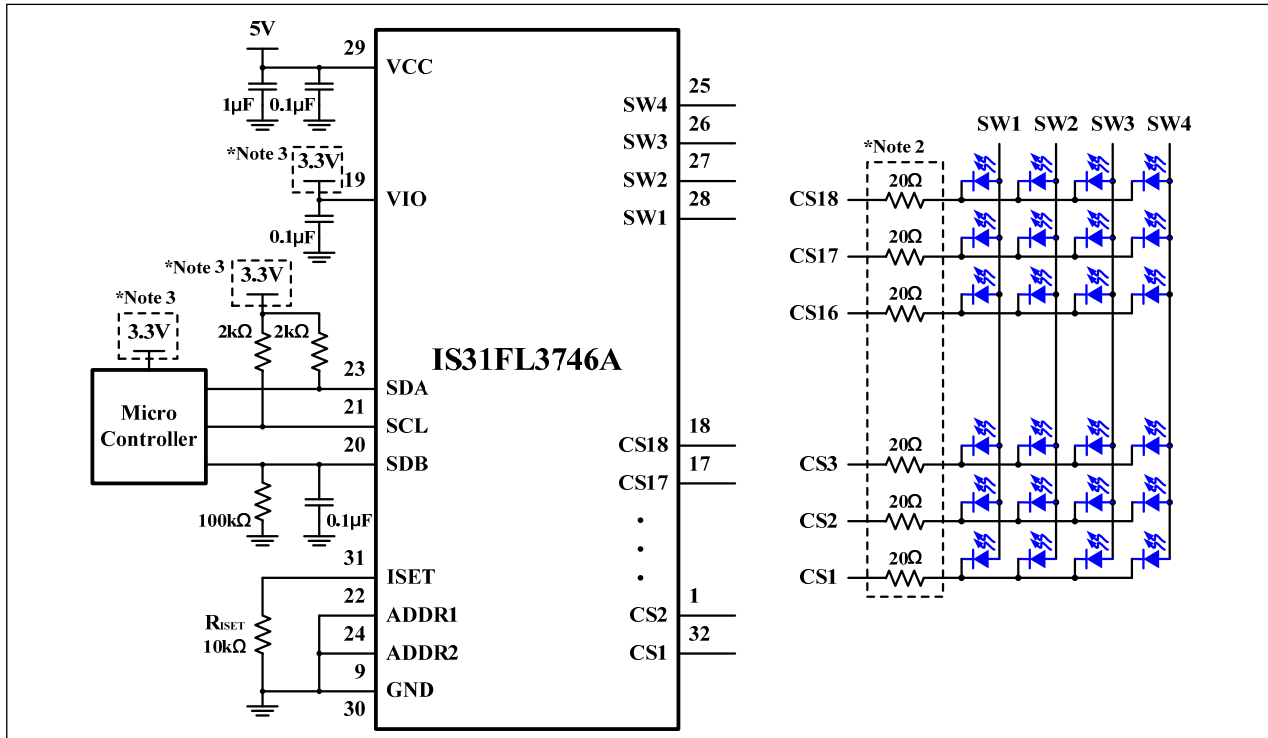

Figure 2 Typical Application Circuit: 72 Mono Color LEDs

Note 1: IC should be placed far away from the antenna in order to prevent the EMI.

Note 2: The 20Ω or 51Ω resistors between LED and IC are only for thermal reduction, for mono red LED, if $V_{CC}=3.3V$, don't need these resistors.

Note 3: The V_{IH} of I2C bus should be same as VIO pin. VIO pin need to connect to a reference voltage and usually it is same as the VCC of MCU. If VCC of MCU is 1.8V, $V_{IO}=1.8V$, if V_{CC} of MCU is 5V, $V_{IO}=5V$.

IS31FL3746A

PIN CONFIGURATION

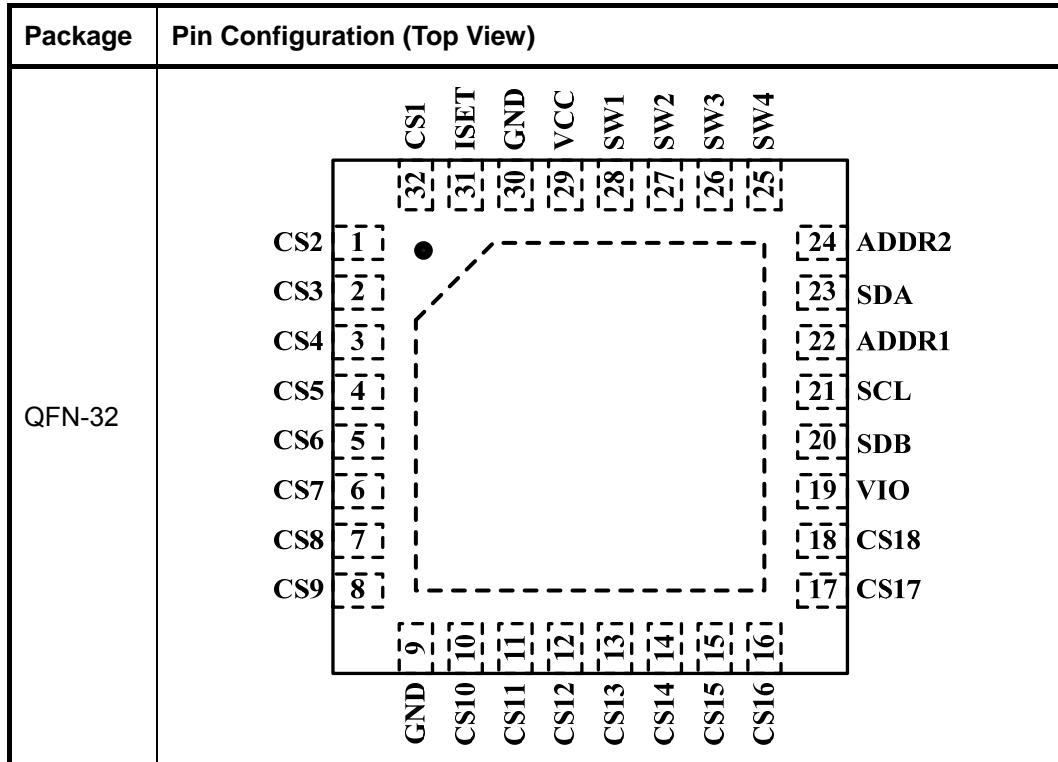

PIN DESCRIPTION

No.	Pin	Description
1~8, 10~18	CS2~CS18	Current sink pin for LED matrix.
9,30	GND	Ground.
19	VIO	Input logic reference voltage, can't be floated.
20	SDB	Shutdown pin.
21	SCL	I2C compatible serial clock.
22	ADDR1	I2C address select.
23	SDA	I2C compatible serial data.
24	ADDR2	I2C address select.
25~28	SW4~SW1	Power SW.
29	VCC	Power for current source SW and analog.
31	ISET	Set the maximum IOU current.
32	CS1	Current sink pin for LED matrix.
	Thermal Pad	Connect to GND.



IS31FL3746A

ORDERING INFORMATION

Industrial Range: -40°C to +125°C

Order Part No.	Package	QTY/Reel
IS31FL3746A-QFLS4-TR	QFN-32, Lead-free	2500

Copyright © 2018 Integrated Silicon Solution, Inc. All rights reserved. ISSI reserves the right to make changes to this specification and its products at any time without notice. ISSI assumes no liability arising out of the application or use of any information, products or services described herein. Customers are advised to obtain the latest version of this device specification before relying on any published information and before placing orders for products. Integrated Silicon Solution, Inc. does not recommend the use of any of its products in life support applications where the failure or malfunction of the product can reasonably be expected to cause failure of the life support system or to significantly affect its safety or effectiveness. Products are not authorized for use in such applications unless Integrated Silicon Solution, Inc. receives written assurance to its satisfaction, that:

- a.) the risk of injury or damage has been minimized;
- b.) the user assume all such risks; and
- c.) potential liability of Integrated Silicon Solution, Inc is adequately protected under the circumstances

IS31FL3746A

ABSOLUTE MAXIMUM RATINGS

Supply voltage, V_{CC}	-0.3V ~ +6.0V
Voltage at any input pin	-0.3V ~ $V_{CC}+0.3V$
Maximum junction temperature, T_{JMAX}	+150°C
Storage temperature range, T_{STG}	-65°C ~ +150°C
Operating temperature range, $T_A=T_J$	-40°C ~ +125°C
Package thermal resistance, junction to ambient (4 layer standard test PCB based on JESD 51-2A), θ_{JA}	52°C/W
ESD (HBM)	±8kV
ESD (CDM)	±750V

Note 4: Stresses beyond those listed under “Absolute Maximum Ratings” may cause permanent damage to the device. These are stress ratings only and functional operation of the device at these or any other condition beyond those indicated in the operational sections of the specifications is not implied. Exposure to absolute maximum rating conditions for extended periods may affect device reliability.

ELECTRICAL CHARACTERISTICS

The following specifications apply for $V_{CC}=5V$, $T_A=25^\circ C$, unless otherwise noted.

Symbol	Parameter	Conditions	Min.	Typ.	Max.	Unit
V_{CC}	Supply voltage		2.7		5.5	V
I_{CC}	Quiescent power supply current	$V_{SDB}=V_{CC}$, all LEDs off		2.3		mA
I_{SD}	Shutdown current	$V_{SDB}=0V$		2.8		μA
		$V_{SDB}=V_{CC}$, Configuration Register written “0000 0000		2.8		
I_{OUT}	Maximum constant current of CSy	$R_{ISET}=10k\Omega$, $GCC=0xFF$ $SL=0xFF$		34.5		mA
I_{LED}	Average current on each LED $I_{LED}=I_{OUT(PEAK)}/Duty(4.14)$	$R_{ISET}=10k\Omega$, $GCC=0xFF$ $SL=0xFF$		8.33		mA
V_{HR}	Current switch headroom voltage SWx	$I_{SWITCH}=612mA$, $R_{ISET}=10k\Omega$, $GCC=0xFF$, $SL=0xFF$		450		mV
	Current sink headroom voltage CSy	$I_{SINK}=34mA$, $R_{ISET}=10k\Omega$, $GCC=0xFF$, $SL=0xFF$		250		
t_{SCAN}	Period of scanning			33		μs
t_{NOL1}	Non-overlap blanking time during scan, the SWx and CSy are all off during this time			0.83		μs
t_{NOL2}	Delay total time for CS1 to CS18, during this time, the SWx is on but CSy is not all turned on	(Note 5)		0.3		μs
Logic Electrical Characteristics (SDA, SCL, ADDR_x, SDB)						
V_{IL}	Logic “0” input voltage	$V_{IO}=1.8V$; $V_{IO}=3.3V$	GND		$0.2V_{IO}$	V
V_{IH}	Logic “1” input voltage	$V_{IO}=1.8V$; $V_{IO}=3.3V$	$0.75V_{IO}$		V_{IO}	V
V_{HYS}	Input Schmitt trigger hysteresis	$V_{IO}=3.3V$		0.2		V
I_{IL}	Logic “0” input current	$V_{INPUT}=0V$ (Note 5)		5		nA
I_{IH}	Logic “1” input current	$V_{INPUT}=V_{IO}$ (Note 5)		5		nA

IS31FL3746A

DIGITAL INPUT I2C SWITCHING CHARACTERISTICS (NOTE 5)

Symbol	Parameter	Fast Mode			Fast Mode Plus			Units
		Min.	Typ.	Max.	Min.	Typ.	Max.	
f_{SCL}	Serial-clock frequency	-		400	-		1000	kHz
t_{BUF}	Bus free time between a STOP and a START condition	1.3		-	0.5		-	μ s
$t_{HD, STA}$	Hold time (repeated) START condition	0.6		-	0.26		-	μ s
$t_{SU, STA}$	Repeated START condition setup time	0.6		-	0.26		-	μ s
$t_{SU, STO}$	STOP condition setup time	0.6		-	0.26		-	μ s
$t_{HD, DAT}$	Data hold time	-		-	-		-	μ s
$t_{SU, DAT}$	Data setup time	100		-	50		-	ns
t_{LOW}	SCL clock low period	1.3		-	0.5		-	μ s
t_{HIGH}	SCL clock high period	0.7		-	0.26		-	μ s
t_R	Rise time of both SDA and SCL signals, receiving	-		300	-		120	ns
t_F	Fall time of both SDA and SCL signals, receiving	-		300	-		120	ns

Note 5: Guaranteed by design.

IS31FL3746A

FUNCTIONAL BLOCK DIAGRAM

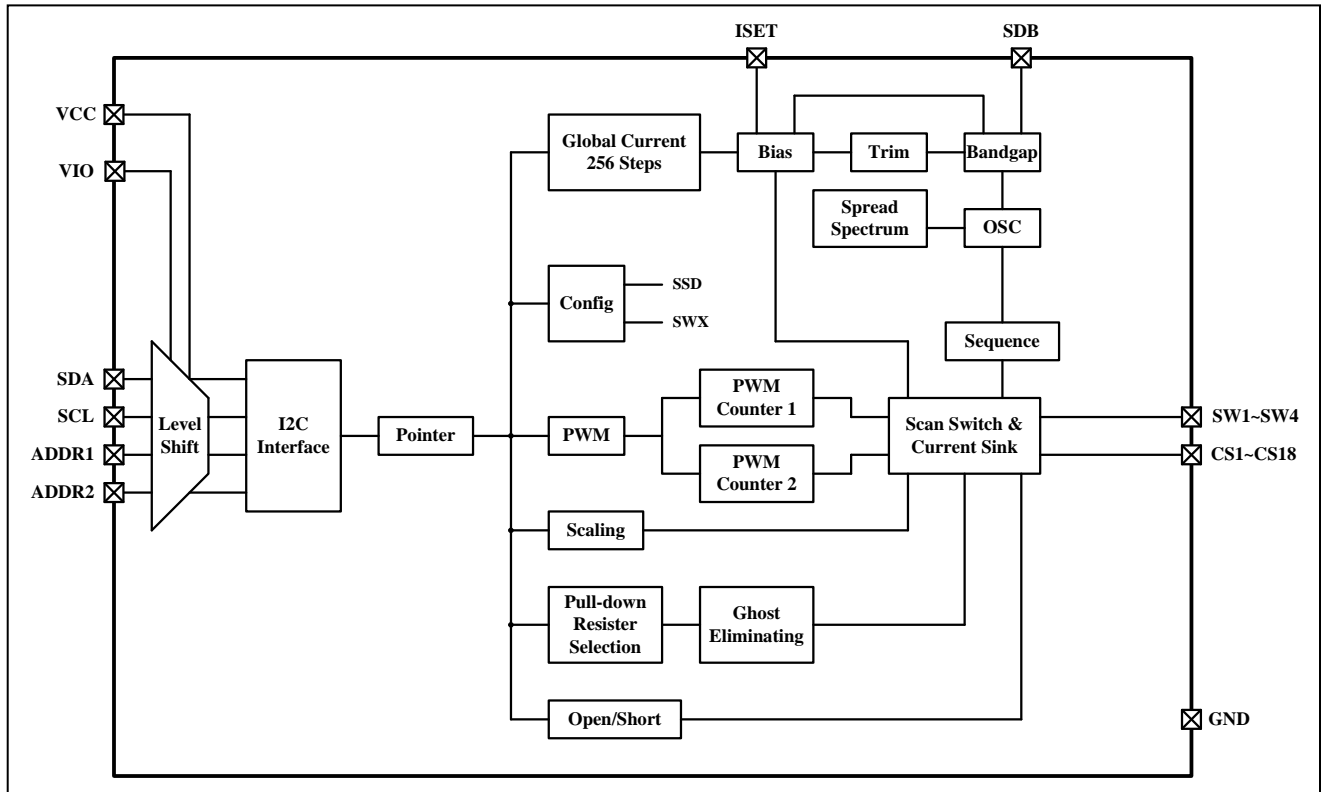

IS31FL3746A

DETAILED DESCRIPTION

I2C INTERFACE

IS31FL3746A uses a serial bus, which conforms to the I2C protocol, to control the chip's functions with two wires: SCL and SDA. The IS31FL3746A has a 7-bit slave address (A7:A1), followed by the R/W bit, A0. Set A0 to "0" for a write command and set A0 to "1" for a read command. The value of bits A1 and A2 are decided by the connection of the ADDR_x pin.

Table 1 Slave Address:

ADDR2	ADDR1	A7:A5	A4:A3	A2:A1	A0
GND	GND	110	00	00	0/1
GND	SCL		00	01	
GND	SDA		00	10	
GND	VCC		00	11	
SCL	GND		01	00	
SCL	SCL		01	01	
SCL	SDA		01	10	
SCL	VCC		01	11	
SDA	GND		10	00	
SDA	SCL		10	01	
SDA	SDA		10	10	
SDA	VCC		10	11	
VCC	GND		11	00	
VCC	SCL		11	01	
VCC	SDA		11	10	
VCC	VCC		11	11	

ADDR1/2 connected to GND, (A2:A1)/(A4:A3)=00;
 ADDR1/2 connected to VCC, (A2:A1)/(A4:A3)=11;
 ADDR1/2 connected to SCL, (A2:A1)/(A4:A3)=01;
 ADDR1/2 connected to SDA, (A2:A1)/(A4:A3)=10;

The SCL line is uni-directional. The SDA line is bi-directional (open-collector) with a pull-up resistor (typically 400kHz I2C with 4.7kΩ, 1MHz I2C with 2kΩ). The maximum clock frequency specified by the I2C standard is 1MHz. In this discussion, the master is the microcontroller and the slave is the IS31FL3746A.

The timing diagram for the I2C is shown in Figure 3. The SDA is latched in on the stable high level of the SCL. When there is no interface activity, the SDA line should be held high.

The "START" signal is generated by lowering the SDA signal while the SCL signal is high. The start signal will alert all devices attached to the I2C bus to check the incoming address against their own chip address.

The 8-bit chip address is sent next, most significant bit first. Each address bit must be stable while the SCL level is high.

After the last bit of the chip address is sent, the master checks for the IS31FL3746A's acknowledge. The master releases the SDA line high (through a pull-up resistor). Then the master sends an SCL pulse. If the IS31FL3746A has received the address correctly, then it holds the SDA line low during the SCL pulse. If the SDA line is not low, then the master should send a "STOP" signal (discussed later) and abort the transfer.

Following acknowledge of IS31FL3746A, the register address byte is sent, most significant bit first. IS31FL3746A must generate another acknowledge indicating that the register address has been received.

Then 8-bit of data byte are sent next, most significant bit first. Each data bit should be valid while the SCL level is stable high. After the data byte is sent, the IS31FL3746A must generate another acknowledge to indicate that the data was received.

The "STOP" signal ends the transfer. To signal "STOP", the SDA signal goes high while the SCL signal is high.

ADDRESS AUTO INCREMENT

To write multiple bytes of data into IS31FL3746A, load the address of the data register that the first data byte is intended for. During the IS31FL3746A acknowledge of receiving the data byte, the internal address pointer will increment by one. The next data byte sent to IS31FL3746A will be placed in the new address, and so on. The auto increment of the address will continue as long as data continues to be written to IS31FL3746A (Figure 6).

READING OPERATION

Most of the registers can be read.

To read the FCh, FEh, after I2C start condition, the bus master must send the IS31FL3746A device address with the R/W bit set to "0", followed by the register address (FEh or F1h) which determines which register is accessed. Then restart I2C, the bus master should send the IS31FL3746A device address with the R/W bit set to "1". Data from the register defined by the command byte is then sent from the IS31FL3746A to the master (Figure 7).

To read the registers of Page 0 thru Page 1, the FDh should write with 00h before follow the Figure 7 sequence to read the data. That means, when you want to read registers of Page 0, the FDh should point to Page 0 first and you can read the Page 0 data.

IS31FL3746A

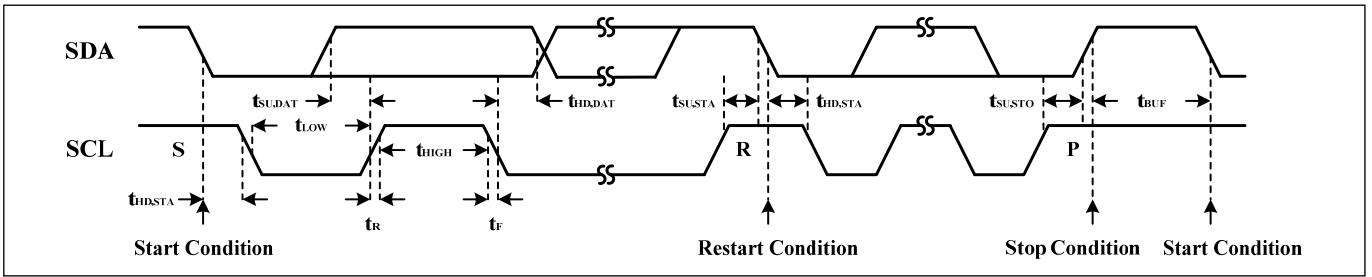

Figure 3 I2C Interface Timing

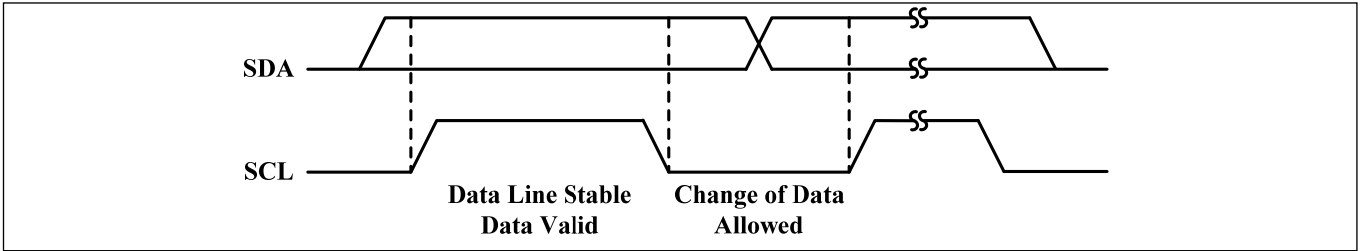

Figure 4 I2C Bit Transfer

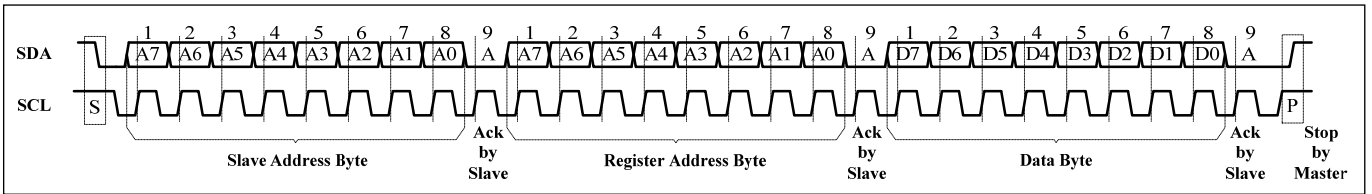

Figure 5 I2C Writing to IS31FL3746A (Typical)

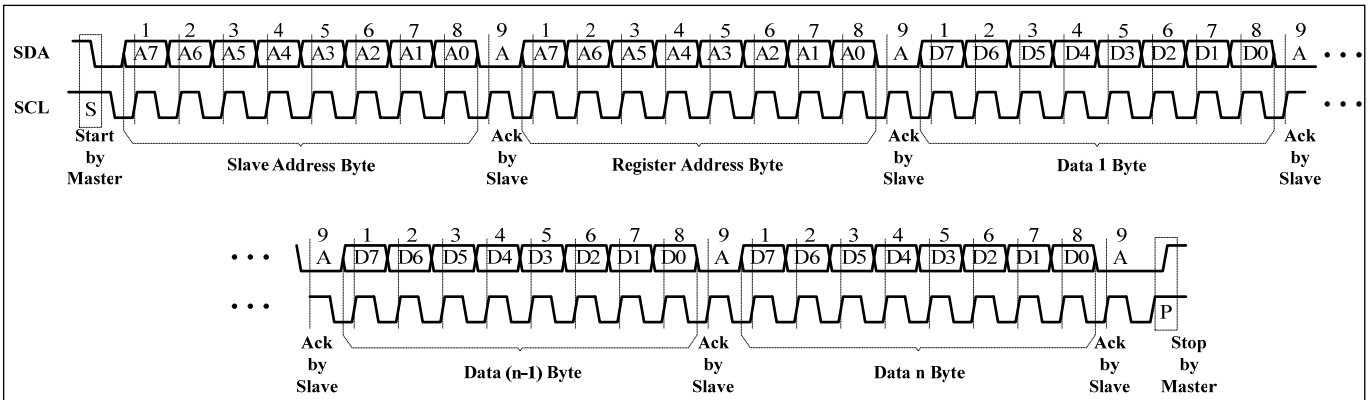

Figure 6 I2C Writing to IS31FL3746A (Automatic Address Increment)

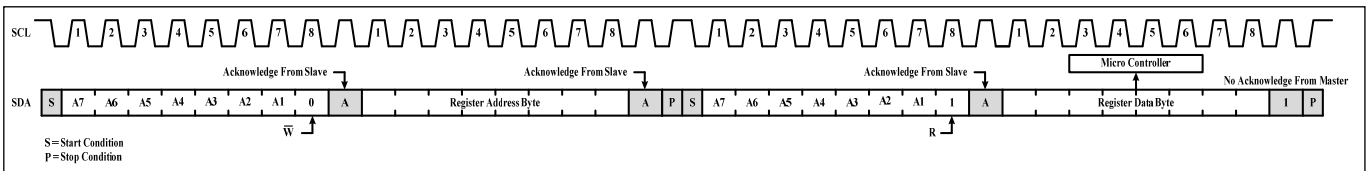

Figure 7 I2C Reading from IS31FL3746A

IS31FL3746A

Table 2 Command Register Definition

Address	Name	Function	Table	R/W	Default
FEh	Command Register Write Lock	To unlock Command Register	4	R/W	0000 0000
FDh	Command Register	Available Page 0 to Page 1 registers	3	W	xxxx xxxx
FCh	ID Register	For read the product ID only; Read result is the slave address	-	R	Slave Address

REGISTER CONTROL

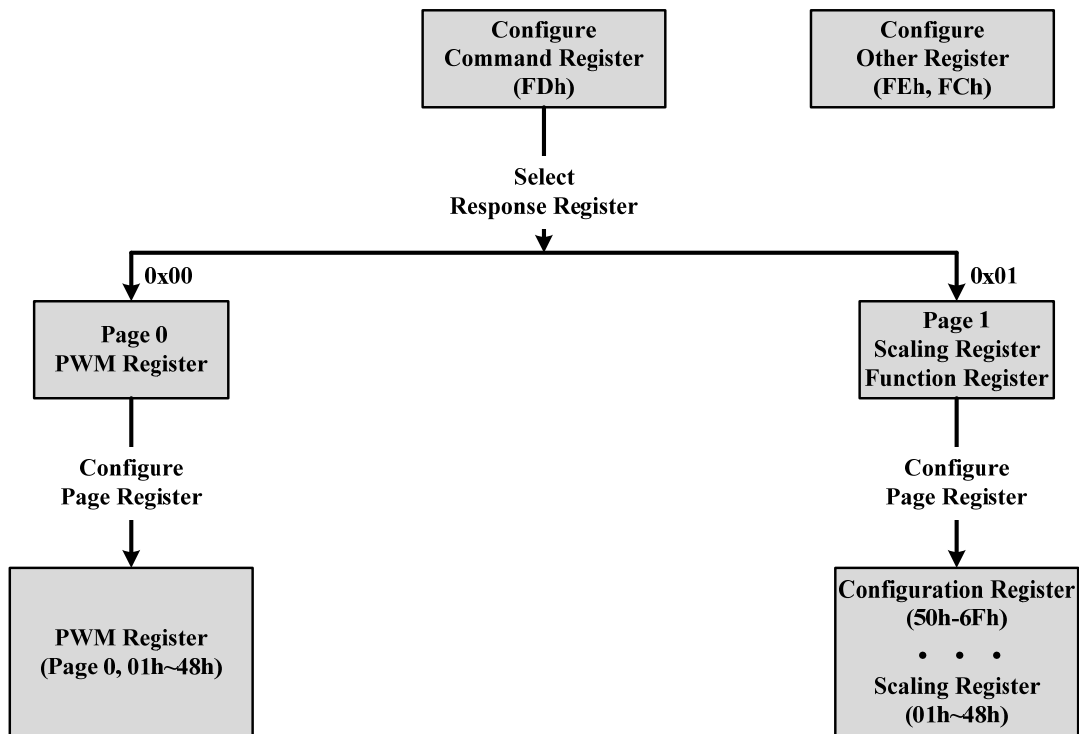

Table 3 FDh Command Register

Data	Function
0000 0000	Point to Page 0 (PG0, PWM Register is available)
0000 0001	Point to Page 1 (PG1, White Balance Scaling and Function Register is available)
Others	Reserved

Note: FDh is locked when power up, need to unlock this register before write command to it. See Table 4 for detail.

The Command Register should be configured first after writing in the slave address to choose the available register. Then write data in the choosing register. Power up default state is "0000 0000".

For example, when write "0000 0001" in the Command Register (FDh), the data which writing after will be stored in PG1 registers. Write new data can configure other registers.

Table 4 FEh Command Register Write Lock (Read/Write)

Bit	D7:D0
Name	CRWL
Default	0000 0000 (FDh write disable)

To select the PG0~PG1, need to unlock this register first, with the purpose to avoid mis-operation of this register. When FEh is written with 0xC5, FDh is allowed to modify once, after the FDh is modified the FEh will reset to be 0x00 at once.

IS31FL3746A

Table 5 Register Definition

Address	Name	Function	Table	R/W	Default
PG0 (0x00): PWM Registers					
01h~48h	PWM Register	Set PWM for each LED	6	R/W	0000 0000
PG1 (0x01): LED Scaling & Function Registers					
01h~48h	Scaling Register	Set Scaling for each LED	7	R/W	0000 0000
50h	Configuration Register	Configure the operation mode	9	R/W	0000 0000
51h	Global Current Control Register	Set the global current	10	R/W	0000 0000
52h	Pull Down/Up Resistor Selection Register	Set the pull down resistor for SWx and pull up resistor for CSy	11	R/W	0011 0011
53h~5Eh	Open/Short Register	Store the open or short information	12	R	0000 0000
5Fh	Temperature Status	Store the temperature point of the IC	13	R/W	0000 0000
60h	Spread Spectrum Register	Spread spectrum function enable	14	R/W	0000 0000
8Fh	Reset Register	Reset all register to POR state	-	W	0000 0000
E0h	PWM Frequency Enable Register	Enable PWM frequency setting	15	W	0000 0000
E2h	PWM Frequency Setting Register	Set the PWM frequency	16	W	000x xxxx

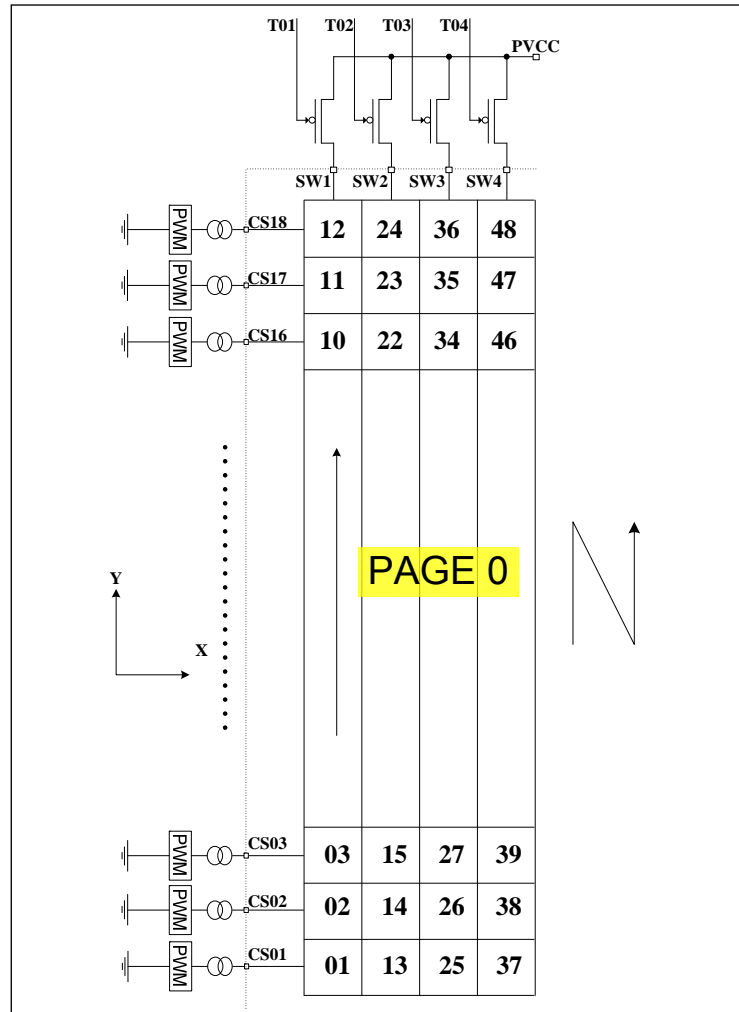

Figure 8 PWM Register

Table 6 PG0: 01h ~ 48h PWM Register

Bit	D7:D0
Name	PWM
Default	0000 0000

Each dot has a byte to modulate the PWM duty in 256 steps.

The value of the PWM Registers decides the average current of each LED noted I_{LED} .

I_{LED} computed by Formula (1):

$$I_{LED} = \frac{PWM}{256} \times I_{OUT(PEAK)} \times Duty \quad (1)$$

$$PWM = \sum_{n=0}^7 D[n] \cdot 2^n$$

Where Duty is the duty cycle of SWx,

$$Duty = \frac{33\mu s}{(33\mu s + 0.83\mu s + 0.3s)} \times \frac{1}{4} = \frac{1}{4.14} \quad (2)$$

I_{OUT} is the output current of CSy (y=1~18),

$$I_{OUT(PEAK)} = \frac{343}{R_{ISET}} \times \frac{GCC}{256} \times \frac{SL}{256} \quad (3)$$

GCC is the Global Current Control Register (PG1, 51h) value, SL is the Scaling Register value as Table 9 and R_{ISET} is the external resistor of ISET pin. D[n] stands for the individual bit value, 1 or 0, in location n.

For example: if D7:D0=1011 0101 (0xB5, 181), GCC=1111 1111, $R_{ISET} = 10k\Omega$, SL=1111 1111:

$$I_{LED} = \frac{343}{10k\Omega} \times \frac{255}{256} \times \frac{255}{256} \times \frac{1}{4.14} \times \frac{181}{256}$$

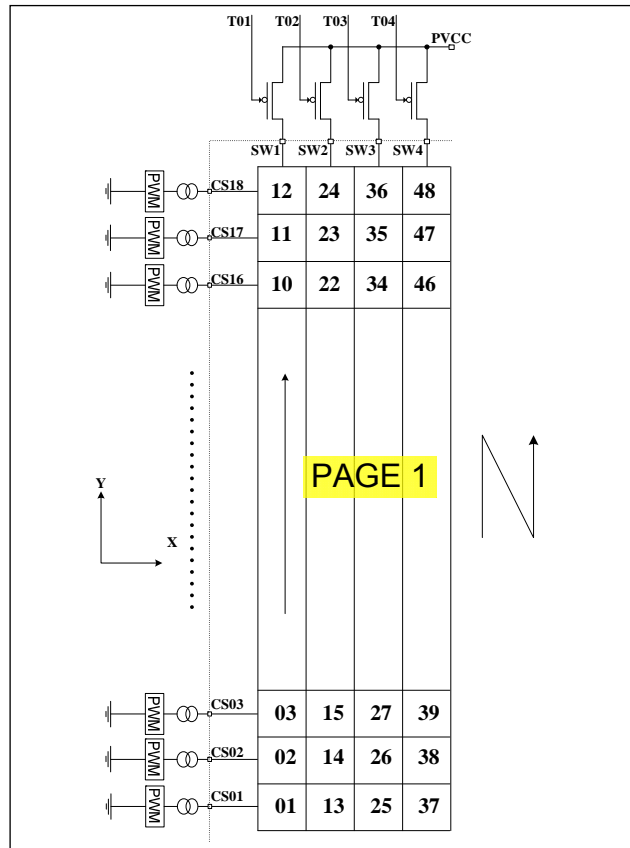

Figure 9 Scaling Register

Table 7 PG1: 01h ~ 48h Scaling Register

Bit	D7:D0
Name	SL
Default	0000 0000

Scaling register control the DC output current of each dot. Each dot has a byte to modulate the scaling in 256 steps.

The value of the Scaling Register decides the peak current of each LED noted $I_{OUT(PEAK)}$.

$I_{OUT(PEAK)}$ computed by Formula (3):

$$I_{OUT(PEAK)} = \frac{343}{R_{ISET}} \times \frac{GCC}{256} \times \frac{SL}{256} \quad (3)$$

$$SL = \sum_{n=0}^7 D[n] \cdot 2^n$$

I_{OUT} is the output current of CSy (y=1~18), GCC is the Global Current Control Register (PG1, 51h) value and R_{ISET} is the external resistor of R_{ISET} pin. D[n] stands for the individual bit value, 1 or 0, in location n.

For example: if $R_{ISET}=10k\Omega$, $GCC=1111\ 1111$, $SL=0111\ 1111$:

$$SL = \sum_{n=0}^7 D[n] \cdot 2^n = 127$$

$$I_{OUT} = \frac{343}{10k\Omega} \times \frac{255}{256} \times \frac{127}{256} = 16.8mA$$

$$I_{LED} = 16.8mA \times \frac{1}{4.14} \times \frac{PWM}{256}$$

IS31FL3746A

Table 8 Page 1 (PG1, FDh= 0x01): Function Register

Register	Name	Function	Table	R/W	Default
50h	Configuration Register	Configure the operation mode	9	R/W	0000 0000
51h	Global Current Control Register	Set the global current	10	R/W	0000 0000
52h	Pull Down/Up Resistor Selection Register	Set the pull down resistor for SWx and pull up resistor for CSy	11	R/W	0011 0011
53h~5Eh	Open/Short Register	Store the open or short information	12	R	0000 0000
5Fh	Temperature Status	Store the temperature point of the IC	13	R/W	0000 0000
60h	Spread Spectrum Register	Spread spectrum function enable	14	R/W	0000 0000
8Fh	Reset Register	Reset all register to POR state	-	W	0000 0000
E0h	PWM Frequency Enable Register	Enable PWM frequency setting	15	W	0000 0000
E2h	PWM Frequency Setting Register	Set the PWM frequency	16	W	000x xxxx

Table 9 50h Configuration Register

Bit	D7:D4	D3	D2:D1	D0
Name	SWS	-	OSDE	SSD
Default	0000	0	00	0

The Configuration Register sets operating mode of IS31FL3746A.

SWS SWx Setting
 0000 SW1~SW4, 1/4
 0001 SW1~SW3, 1/3, SW4 no-active
 0010 SW1~SW2, 1/2, SW3~SW4 no-active
 0011 All CSy work as current sinks only, no scan
 Others SW1~SW4, 1/4

OSDE Open Short Detection Enable
 00 Disable open/short detection
 01/11 Enable open detection
 10 Enable short detection

SSD Software Shutdown Control
 0 Software shutdown
 1 Normal operation

When OSDE set to "01", open detection will be trigger once, the user could trigger open detection again by set OSDE from "00" to "01".

When OSDE set "10", short detection will be trigger once, the user could trigger short detection again by set OSDE from "00" to "10".

When SSD is "0", IS31FL3746A works in software shutdown mode and to normal operate the SSD bit should set to "1".

SWS control the duty cycle of the SWx, default mode is 1/4.

Table 10 51h Global Current Control Register

Bit	D7:D0
Name	GCC
Default	0000 0000

The Global Current Control Register modulates all CSy (y=1~18) DC current which is noted as I_{OUT} in 256 steps.

I_{OUT} is computed by the Formula (3):

$$I_{OUT(PEAK)} = \frac{343}{R_{SET}} \times \frac{GCC}{256} \times \frac{SL}{256} \quad (3)$$

$$GCC = \sum_{n=0}^7 D[n] \cdot 2^n$$

Where D[n] stands for the individual bit value, 1 or 0, in location n.

Table 11 52h Pull Down/Up Resistor Selection Register

Bit	D7	D6:D4	D3	D2:D0
Name	PHC	SWPDR	-	CSPUR
Default	0	011	0	011

Set pull down resistor for SWx and pull up resistor for CSy.

PHC Phase Choice
 0 0 degree phase delay
 1 180 degree phase delay

IS31FL3746A

SWPDR	SWx Pull Down Resistor Selection Bit
000	No pull down resistor
001	0.5kΩ only in SWx off time
010	1.0kΩ only in SWx off time
011	2.0kΩ only in SWx off time
100	1.0kΩ all the time
101	2.0kΩ all the time
110	4.0kΩ all the time
111	8.0kΩ all the time

CSPUR	CSy Pull up Resistor Selection Bit
000	No pull up resistor
001	0.5kΩ only in CSy off time
010	1.0kΩ only in CSy off time
011	2.0kΩ only in CSy off time
100	1.0kΩ all the time
101	2.0kΩ all the time
110	4.0kΩ all the time
111	8.0kΩ all the time

Table 12 53h~5Eh Open/Short Register (Read Only)

Bit	D7:D6	D5:D0
Name	-	CS18:CS13, CS12:CS07,CS06:CS01
Default	00	00 0000

When OSDE (PG1, 50h) is set to "01", open detection will be trigger once, and the open information will be stored at 53h~5Eh.

When OSDE (PG1, 50h) set to "10", short detection will be trigger once, and the short information will be stored at 53h~5Eh.

Before set OSDE, the GCC should set to 0x0F~0x40 and the 52h should set to 0x00.

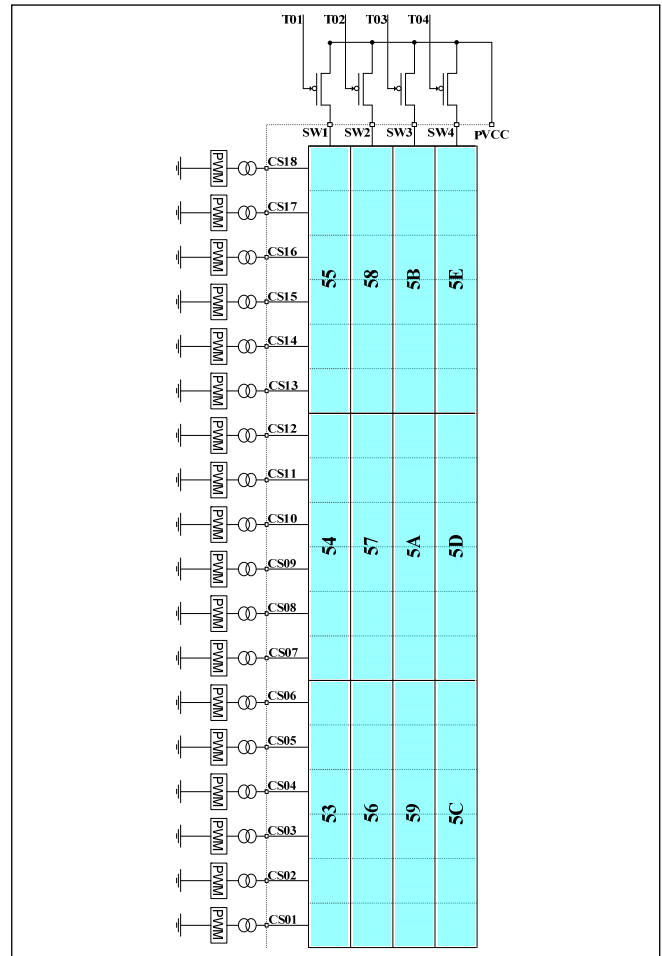

Figure 10 Open/Short Register

Table 13 5Fh Temperature Status

Bit	D7:D4	D3:D2	D1:D0
Name	-	TS	TROF
Default	0000	00	00

TS store the temperature point of the IC. If the IC temperature reaches the temperature point the IC will trigger the thermal roll off and will decrease the current as TROF set percentage.

TS	Temperature Point (Thermal Roll Off Start Point)
00	140°C
01	120°C
10	100°C
11	90°C

TROF	Percentage Of Output Current
00	100%
01	75%
10	55%
11	30%

IS31FL3746A

Table 14 60h Spread Spectrum Register

Bit	D7:D6	D4	D3:D2	D1:D0
Name	-	SSP	RNG	CLT
Default	00	0	00	00

When SSP enable, the spread spectrum function will be enabled and the RNG & CLT bits will adjust the range and cycle time of spread spectrum function.

SSP Spread Spectrum Function Enable
 0 Disable
 1 Enable

RNG Spread Spectrum Range
 00 ±5%
 01 ±15%
 10 ±24%
 11 ±34%

CLT Spread Spectrum Cycle Time
 00 1980µs
 01 1200µs
 10 820µs
 11 660µs

8Fh Reset Register

Once user writes the Reset Register with 0xAE, IS31FL3746A will reset all the IS31FL3746A registers to their default value. On initial power-up, the IS31FL3746A registers are reset to their default values for a blank display.

Table 15 E0h PWM Frequency Enable Register

Bit	D7:D1	D0
Name	-	PFEN
Default	0000 000	0

The PWM Frequency Enable Register enables or disables to change the PWM frequency. If PFEN= "1", user can change the PWM frequency by modifying the E2h register.

PFEN PWM Frequency Enable
 0 Disable
 1 Enable

Table 16 E2h PWM Frequency Setting Register

Bit	D7:D5	D4:D0
Name	PF	-
Default	000	x xxxx

PWM Frequency Setting Register is used to set the PWM frequency.

PF PWM Frequency
 000/111 29kHz
 001 14.5kHz
 010 7.25kHz
 011 3.63kHz
 100 1.81kHz
 101 906Hz
 110 453Hz

APPLICATION INFORMATION

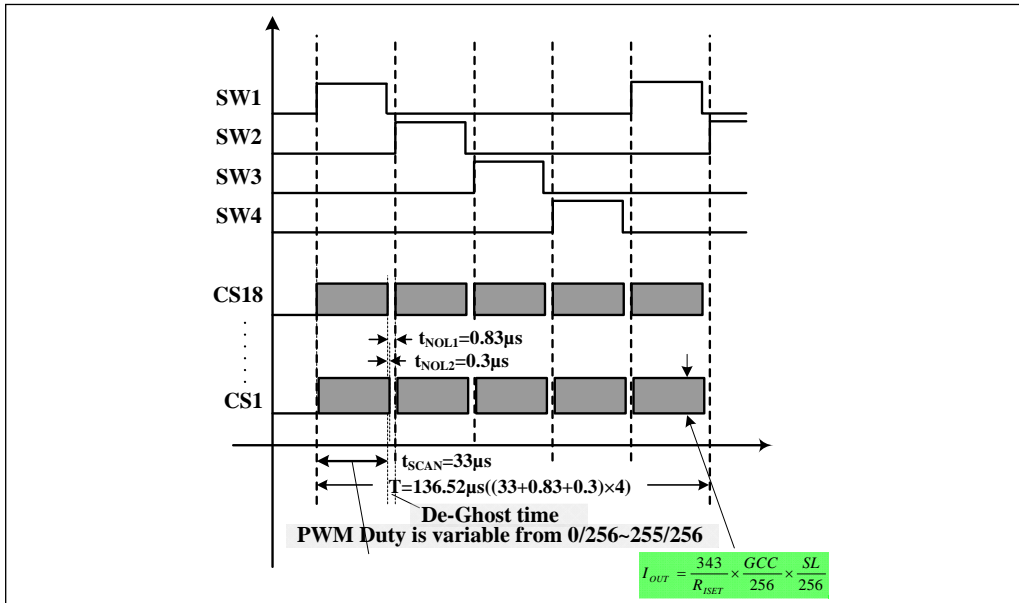

Figure 11 Scanning Timing

SCANNING TIMING

As shown in Figure 11, the SW1~SW4 is turned on by serial, LED is driven 4 by 4 within the SWx (x=1~4) on time (SWx, x=1~4 is source and it is high when LED on), including the non-overlap blanking time during scan, the duty cycle of SWx (active high, x=1~4) is:

$$Duty = \frac{33\mu s}{(33\mu s + 0.83\mu s + 0.3\mu s)} \times \frac{1}{4} = \frac{1}{4.14} \quad (2)$$

Where 33µs is t_{SCAN} , the period of scanning, 0.83µs is t_{NOL1} , 0.3µs is t_{NOL2} , the non-overlap time and CSy(y=1~18) delay time.

PWM CONTROL

After setting the I_{OUT} and GCC, the brightness of each LEDs (LED average current (I_{LED})) can be modulated with 256 steps by PWM Register, as described in Formula (1).

$$I_{LED} = \frac{PWM}{256} \times I_{OUT(PEAK)} \times Duty \quad (1)$$

Where PWM is PWM Registers (PG0, 01h~48h / PG0) data showing in Table 6.

For example, in Figure 1, if $R_{SET} = 10k\Omega$, PWM = 255, and GCC = 255, SL = 255, then

$$I_{OUT(PEAK)} = \frac{243}{10k\Omega} \times \frac{255}{256} \times \frac{255}{256} = 34mA$$

$$I_{LED} = I_{OUT(PEAK)} \times \frac{1}{4.14} \times \frac{PWM}{256}$$

Writing new data continuously to the registers can modulate the brightness of the LEDs to achieve a breathing effect.

GAMMA CORRECTION

In order to perform a better visual LED breathing effect we recommend using a gamma corrected PWM value to set the LED intensity. This results in a reduced number of steps for the LED intensity setting, but causes the change in intensity to appear more linear to the human eye.

Gamma correction, also known as gamma compression or encoding, is used to encode linear luminance to match the non-linear characteristics of display. Since the IS31FL3746A can modulate the brightness of the LEDs with 256 steps, a gamma correction function can be applied when computing each subsequent LED intensity setting such that the changes in brightness matches the human eye's brightness curve.

Table 17 32 Gamma Steps with 256 PWM Steps

C(0)	C(1)	C(2)	C(3)	C(4)	C(5)	C(6)	C(7)
0	1	2	4	6	10	13	18
C(8)	C(9)	C(10)	C(11)	C(12)	C(13)	C(14)	C(15)
22	28	33	39	46	53	61	69
C(16)	C(17)	C(18)	C(19)	C(20)	C(21)	C(22)	C(23)
78	86	96	106	116	126	138	149
C(24)	C(25)	C(26)	C(27)	C(28)	C(29)	C(30)	C(31)
161	173	186	199	212	226	240	255

IS31FL3746A

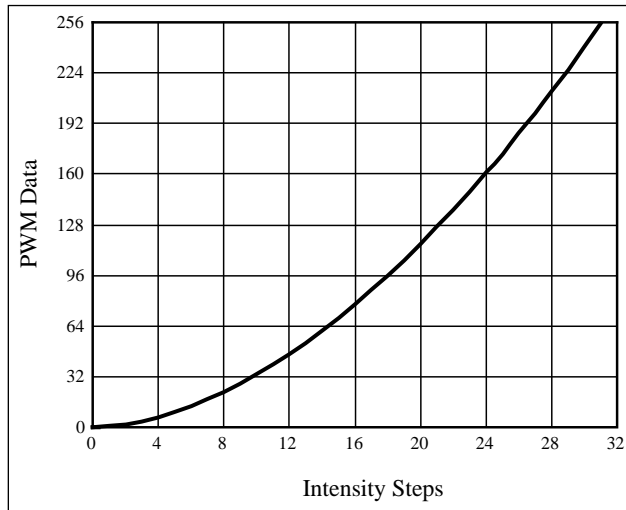

Figure 12 Gamma Correction (32 Steps)

Choosing more gamma steps provides for a more continuous looking breathing effect. This is useful for very long breathing cycles. The recommended configuration is defined by the breath cycle T. When T=1s, choose 32 gamma steps, when T=2s, choose 64 gamma steps. The user must decide the final number of gamma steps not only by the LED itself, but also based on the visual performance of the finished product.

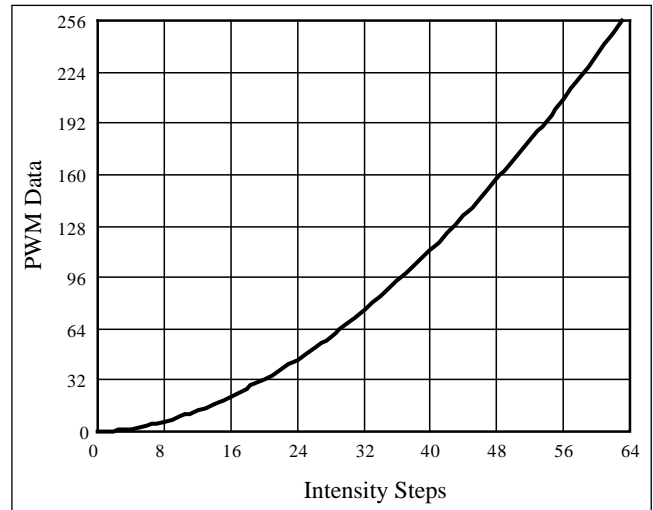

Figure 13 Gamma Correction (64 Steps)

Note: The data of 32 gamma steps is the standard value and the data of 64 gamma steps is the recommended value.

OPERATING MODE

IS31FL3746A can only operate in PWM Mode. The brightness of each LED can be modulated with 256 steps by PWM registers. For example, if the data in PWM Register is “0000 0100”, then the PWM is the fourth step.

Writing new data continuously to the registers can modulate the brightness of the LEDs to achieve a breathing effect.

OPEN/SHORT DETECT FUNCTION

IS31FL3746A has open and short detect bit for each LED.

By setting the OSD bits of the Configuration Register (PG1, 50h) from “00” to “01” or “10”, the LED Open/short Register will start to store the open/short information and after at least 2 scanning cycles and the MCU can get the open/short information by reading the 53h~5Eh, for those dots are turned off via LED Scaling Registers (PG1, 01h~48h), the open/short data will not get refreshed when setting the OSD bit of the Configuration Register.

To get the correct open and short information, two configurations need to set before setting the OSD bits:

- 1 0x0F ≤ GCC ≤ 0x40
- 2 52h = 0x00

Where GCC is the Global Current Control Register (PG1, 51h) and 52h is the Pull Down/UP Resistor Selection Register and set to 0x00 is to disable the SWx pull-down and CSx pull-up function.

The detect action is one-off event and each time before reading out the open/short information, the OSDE bit of the Configuration Register (PG1, 50h) need to be set from “00” to “01”/ “10” (clear before set operation).

Table 18 64 Gamma Steps with 256 PWM Steps

C(0)	C(1)	C(2)	C(3)	C(4)	C(5)	C(6)	C(7)
0	1	2	3	4	5	6	7
C(8)	C(9)	C(10)	C(11)	C(12)	C(13)	C(14)	C(15)
8	10	12	14	16	18	20	22
C(16)	C(17)	C(18)	C(19)	C(20)	C(21)	C(22)	C(23)
24	26	29	32	35	38	41	44
C(24)	C(25)	C(26)	C(27)	C(28)	C(29)	C(30)	C(31)
47	50	53	57	61	65	69	73
C(32)	C(33)	C(34)	C(35)	C(36)	C(37)	C(38)	C(39)
77	81	85	89	94	99	104	109
C(40)	C(41)	C(42)	C(43)	C(44)	C(45)	C(46)	C(47)
114	119	124	129	134	140	146	152
C(48)	C(49)	C(50)	C(51)	C(52)	C(53)	C(54)	C(55)
158	164	170	176	182	188	195	202
C(56)	C(57)	C(58)	C(59)	C(60)	C(61)	C(62)	C(63)
209	216	223	230	237	244	251	255

IS31FL3746A

DE-GHOST FUNCTION

The “ghost” term is used to describe the behavior of an LED that should be OFF but instead glows dimly when another LED is turned ON. A ghosting effect typically can occur when multiplexing LEDs. In matrix architecture any parasitic capacitance found in the constant-current outputs or the PCB traces to the LEDs may provide sufficient current to dimly light an LED to create a ghosting effect.

To prevent this LED ghost effect, the IS31FL3746A has integrated Pull down resistors for each SWx ($x=1\sim 4$) and Pull up resistors for each CSy ($y=1\sim 18$). Select the right SWx Pull down resistor (PG1, 52h) and CSy Pull up resistor (PG1, 52h) which eliminates the ghost LED for a particular matrix layout configuration.

Typically, selecting the 8k Ω will be sufficient to eliminate the LED ghost phenomenon.

The SWx pull down resistors and CSy pull up resistors are active only when the CSy/SWx output working the OFF state and therefore no power is lost through these resistors.

When IS31FL3746A works in hardware shutdown mode, the de-ghost function should be disabled, otherwise it will be extra about 1 μ A shutdown current.

I2C RESET

The I2C will be reset if the SDB pin is pull-high from 0V to logic high, at the operating SDB rising edge, the I2C operation is not allowed.

SHUTDOWN MODE

Shutdown mode can be used as a means of reducing power consumption. During shutdown mode all registers retain their data.

Software Shutdown

By setting SSD bit of the Configuration Register (PG1, 50h) to “0”, the IS31FL3746A will operate in software shutdown mode. When the IS31FL3746A is in software shutdown, all current sources are switched off, so that the matrix is blanked. All registers can be operated. Typical current consume is 2.8 μ A.

Hardware Shutdown

The chip enters hardware shutdown when the SDB pin is pulled low. All analog circuits are disabled during hardware shutdown, typical the current consume is 2.8 μ A.

The chip releases hardware shutdown when the SDB pin is pulled high. During hardware shutdown state Function Register can be operated.

If V_{CC} has risk drop below 1.75V but above 0.1V during SDB pulled low, please re-initialize all Function Registers before SDB pulled high.

LAYOUT

The IS31FL3746A consumes lots of power so good PCB layout will help improve the reliability of the chip. Please consider below factors when layout the PCB.

Power Supply Lines

When designing the PCB layout pattern, the first step should consider about the supply line and GND connection, especially those traces with high current, also the digital and analog blocks' supply line and GND should be separated to avoid the noise from digital block affect the analog block.

At least one 0.1 μ F capacitor, if possible with a 0.47 μ F or 1 μ F capacitor is recommended to connected to the ground at each power supply pins of the chip, and it needs to close to the chip and the ground net of the capacitor should be well connected to the GND plane.

R_{ISET}

R_{ISET} should be close to the chip and the ground side should well connect to the GND plane.

Thermal Consideration

The over temperature of the chip may result in deterioration of the properties of the chip. IS31FL3746A has thermal pad but the chip could be very hot if power is very large. So do consider the ground area connects to the GND pins and thermal pad. Other traces should keep away and ensure the ground area below the package is integrated, and the back layer should be connected to the thermal pad thru 9 or 16 vias to be maximized the area size of ground plane.

IS31FL3746A

Current Rating Example

For a $R_{SET}=10k\Omega$ application, the current rating for each net is as follows:

- VCC and SWx pins= $34mA \times 18=612mA$, recommend trace width: 0.2032mm~0.5mm.
- CSy pins= 34mA, recommend trace width: 0.1016mm~0.254mm.
- All other pins < 3mA, recommend trace width: 0.1016mm~0.254mm.

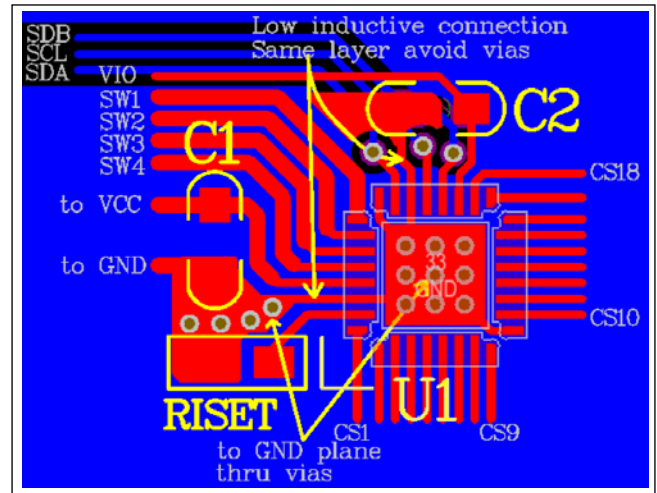

Figure 14 Layout Example

IS31FL3746A

CLASSIFICATION REFLOW PROFILES

Profile Feature	Pb-Free Assembly
Preheat & Soak Temperature min (T _{smin}) Temperature max (T _{smax}) Time (T _{smin} to T _{smax}) (t _s)	150°C 200°C 60-120 seconds
Average ramp-up rate (T _{smax} to T _p)	3°C/second max.
Liquidous temperature (T _L) Time at liquidous (t _L)	217°C 60-150 seconds
Peak package body temperature (T _p)*	Max 260°C
Time (t _p)** within 5°C of the specified classification temperature (T _c)	Max 30 seconds
Average ramp-down rate (T _p to T _{smax})	6°C/second max.
Time 25°C to peak temperature	8 minutes max.

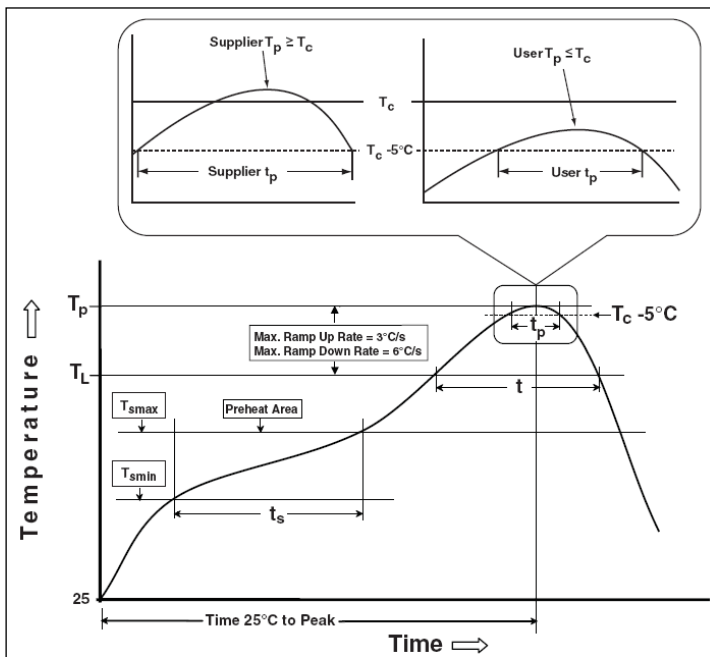
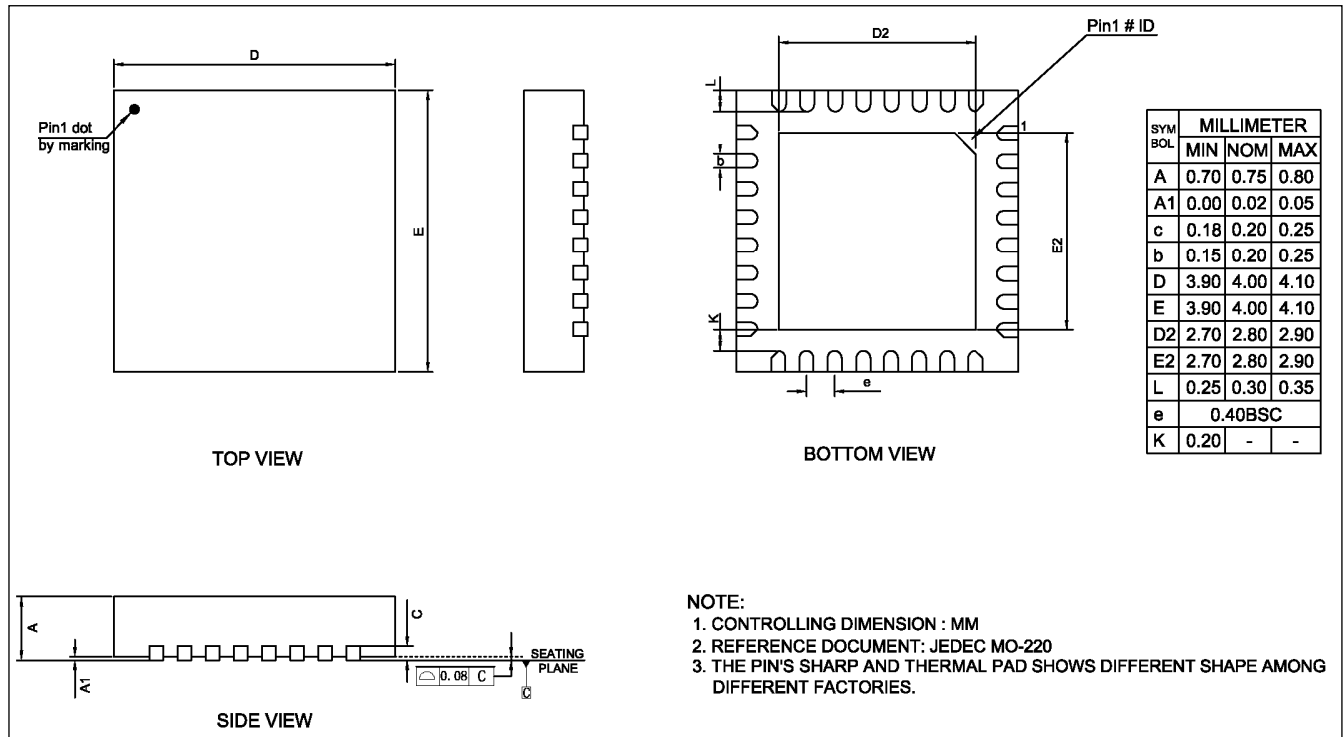

Figure 15 Classification Profile

IS31FL3746A

PACKAGE INFORMATION

QFN-32



IS31FL3746A

RECOMMENDED LAND PATTERN

QFN-32

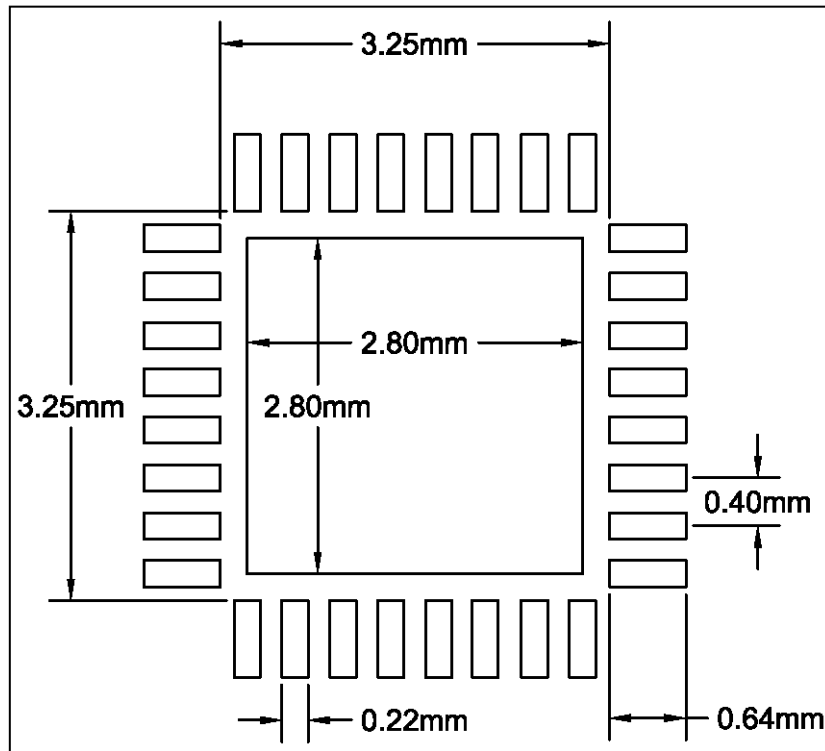

Note:

1. Land pattern complies to IPC-7351.
2. All dimensions in MM.
3. This document (including dimensions, notes & specs) is a recommendation based on typical circuit board manufacturing parameters. Since land pattern design depends on many factors unknown (eg. User's board manufacturing specs), user must determine suitability for use.



IS31FL3746A

REVISION HISTORY

Revision	Detail Information	Date
0A	Initial release	2018.08.16
A	Update to final version	2018.10.22
B	Update Land pattern and functional block	2018.12.19